

**HP Apollo 9000 Model 750
Owner's Guide
for HP-UX Users**

HP 9000 Series 700 Computers



**HP Part No. A1961-90000
Printed in USA June 1991**

**Edition 1
E0691**

Legal Notices

The information in this document is subject to change without notice.

Hewlett-Packard makes no warranty of any kind with regard to this manual, including, but not limited to, the implied warranties of merchantability and fitness for a particular purpose. Hewlett-Packard shall not be held liable for errors contained herein or direct, indirect, special, incidental or consequential damages in connection with the furnishing, performance, or use of this material.

Warranty. A copy of the specific warranty terms applicable to your Hewlett-Packard product and replacement parts can be obtained from your local Sales and Service Office.

©copyright 1983-91 Hewlett-Packard Company

This document contains information which is protected by copyright. All rights are reserved. Reproduction, adaptation, or translation without prior written permission is prohibited, except as allowed under the copyright laws.

Restricted Rights Legend. Use, duplication or disclosure by the U.S. Government is subject to restrictions as set forth in subparagraph (c) (1) (ii) of the Rights in Technical Data and Computer Software clause at DFARS 252.227-7013 for DOD agencies, and subparagraphs (c) (1) and (c) (2) of the Commercial Computer Software Restricted Rights clause at FAR 52.227-19 for other agencies.

HEWLETT-PACKARD COMPANY
3000 Hanover Street
Palo Alto, California 94304 U.S.A.

©copyright 1980, 84, 86 AT&T Technologies, Inc.

UNIX is a registered trademark of Unix System Laboratories Inc. in the USA and other countries.

©copyright 1979, 80, 83, 85-90 Regents of the University of California
This software is based in part on the Fourth Berkeley Software Distribution
under license from the Regents of the University of California.

Printing History

The manual printing date and part number indicate its current edition. The printing date will change when a new edition is printed. Minor changes may be made at reprint without changing the printing date. The manual part number will change when extensive changes are made.

Manual updates may be issued between editions to correct errors or document product changes. To ensure that you receive the updated or new editions, you should subscribe to the appropriate product support service. See your HP sales representative for details.

June 1991 ... Edition 1.

Safety Symbols and Conventions

The following conventions are used throughout this manual:

Note Notes contain important information set off from the text.

Caution Caution messages indicate procedures which, if not observed, could result in loss of data or damage to equipment. Do not proceed beyond a CAUTION sign until the indicated conditions are fully understood and met.

Warning **Warning messages indicate procedures or practices which, if not observed, could result in personal injury. Do not proceed beyond a WARNING sign until the indicated conditions are fully understood and met.**

Warnings and Cautions

WARNING: Removing device cover may expose sharp edges in equipment chassis. To avoid injury, use care when installing customer add-on devices.

WARNUNG: Das Entfernen der Geräteabdeckung legt die scharfen Kanten im Inneren des Gerätes frei. Um Verletzungen zu vermeiden, seien Sie vorsichtig beim Einbau von zusätzlichen Bauteilen, die vom Kunden selber eingebaut werden können.

ADVERTISSEMENT: Des bords tranchants du châssis de l'équipement peuvent être exposés quand le cache de l'unité n'est pas en place. Pour éviter des blessures, faire très attention lors de l'installation de modules supplémentaires par le client.

WARNING: To avoid personal injury and to prevent possible equipment damage, ensure that the ac power is off and the ac power cord is disconnected.

WARNUNG: Um Verletzungen und mögliche Ausrüstungsschäden zu verhindern, muß die Wechselstromquelle ausgeschaltet sein und das Wechselstromzuführungskabel aus der Steckdose entfernt sein.

ADVERTISSEMENT: Pour éviter les risques de blessures et de dommages au matériel, s'assurer que le système n'est pas sous tension et que le fil d'alimentation électrique c.a. est débranché.

WARNING: Disconnect power plug from wall outlet or source power before moving or removing the device, or installing add-on components.

WARNUNG: Entfernen Sie die Stromzuführung von der Steckdose oder der Stromquelle bevor Sie das Gerät bewegen, abbauen, oder zusätzliche Bauteile installieren.

ADVERTISSEMENT: Débrancher la fiche de la prise de courant ou de la source d'alimentation électrique avant de déplacer ou de retirer l'unité, ou avant d'installer des modules supplémentaires.

WARNING: Lifting the 19-inch monitor requires more than one person because the unit weighs more than 40 pounds (18 kilograms).

WARNUNG: Der 19-inch (48 cm) Bildschirm muß von mehreren Personen angehoben werden, da die Einheit über 40 Pfund (18 Kilogramm) wiegt.

ADVERTISSEMENT: Il faut plus d'une personne pour soulever le moniteur de 48 cm (19 pouces) étant donné qu'il pèse plus de 18 kg.

CAUTION: Monitor input voltage must be the same as the system's input voltage.

VORSICHT: Die Bildschirm-Eingangsspannung muß genauso groß sein wie die Eingangsspannung des Systems.

ATTENTION: La tension d'entrée du moniteur doit être la même que la tension d'entrée du système.

CAUTION: Do not unplug the monitor video cable while the system unit is powered on.

VORSICHT: Ziehen Sie nicht das Stromzuführungskabel zum Bildschirm aus der Steckdose, solange das Gerät eingeschaltet ist.

ATTENTION: Ne pas débrancher le câble vidéo du moniteur pendant que l'unité est alimentée.

CAUTION: System power cord must be plugged into an accessible dedicated ac mains receptacle.

VORSICHT: Das System-Netzanschlußkabel muß an eine zugängliche spezielle Wechselstrom-Hauptzuführungssteckdose angeschlossen werden.

ATTENTION: Le fil d'alimentation électrique du système doit être branché dans une prise de courant c.a. spécialisée accessible.

CAUTION: Monitor screen damage will occur if the monitor is left on for extended periods of time with the same image on the screen at high intensity.

VORSICHT: Bildschirmschaden ist unvermeidlich, falls der Bildschirm über längere Zeit und mit demselben Bild auf dem Schirm bei hoher Intensität angeschaltet bleibt.

ATTENTION: L'écran du moniteur sera endommagé si le moniteur est laissé pendant une période prolongée avec la même image sur l'écran à haute intensité.

Laser Safety Statement (For U.S.A. Only)

(For computers with a CD ROM disk drive installed.)

The CD ROM mass storage system is certified as a Class 1 laser product under the U.S. Department of Health and Human Services (DHHS) Radiation Performance Standard according to the *Radiation Control for Health and Safety Act* of 1968.

This means that the mass storage system does not produce hazardous laser radiation. Since laser light emitted inside the mass storage system is completely confined within protective housings and external covers, the laser beam cannot escape from the machine during any phase of user operation.

Warning

- **Use of controls, adjustments, or performing procedures different from those specified in this manual may result in hazardous invisible laser radiation exposure. None of the mechanisms within the mass storage system contain customer or field-replaceable parts.**
 - **The CD ROM drive becomes a Class 3B laser mechanism when disassembled. If the CD ROM drive is disassembled, exposure to the invisible laser beam and hazardous invisible laser radiation could result in blindness. *Do NOT disassemble the CD ROM drive for any reason.***
-

Related Learning Products

Many of Table 0-1 HP-UX learning products are referred to in this book. Others in this list may be useful in helping you to make better use of your system.

Table 0-1. HP-UX Learning Products

Title	HP part number
<i>HP-UX Reference</i>	B2355-90004
<i>System Administration Tasks</i>	B2355-90003
<i>Installation Guide for HP Apollo 9000 Model 750 Workstations and Servers</i>	A1961-90001
<i>Installing Peripherals</i>	B2355-90006
<i>E/ISA Configuration Guide for HP-UX: HP 9000 Series 700 Computers</i>	B2355-90012
<i>A Beginner's Guide to HP-UX</i>	B1862-90000
<i>A User's Guide to HP-UX Shells</i>	B1862-90017
<i>HP Visual User Environment User's Guide</i>	B1171-90022
<i>The HP Visual User Environment System Administration Manual</i>	B1171-90023
<i>Using the X Window System</i>	B1171-90037
<i>Using DEX and SAX with HP-UX</i>	A1926-90002
<i>Managing Clusters of HP 9000 Computers</i>	B2355-90009
<i>How HP-UX Works: Concepts for the System Administrator</i>	B2355-90005
<i>Installing and Updating HP-UX</i>	B2355-90000
<i>HP-UX System Security</i>	B1862-90009
<i>Solving HP-UX Problems</i>	B1862-90010

Welcome!

Welcome to the worldwide community of HP Apollo workstation users.

The *HP Apollo 9000 Model 750 Owner's Guide* describes your HP Apollo 9000 Model 750 computer. It also refers to other documents that you have received with your computer and its system software or which you may order separately.

In this section you will find information about the organization of this guide and the audience for which it is intended. You will also find references to other documents and directions for you to comment upon or ask questions about this guide.

How to Use This Guide

Use this guide to learn about these things:

- how to start up your system
- how to interact with your computer
- how to change your computer's configuration by adding, replacing, or removing internal parts like memory cards and disk drives
- how to determine the cause of problems with the system hardware

This guide will either give specific directions for each of these matters or direct you to other documents or online resources that will explain how to do these things.

When to Use This Guide

Use this guide *after* you have installed your system. To install your system follow the instructions in the *Installation Guide for HP Apollo 9000 Model 750 Workstations and Servers*.

How This Guide Is Organized

Each chapter contains specific information about your system.

- Read Chapter 1 to learn about your computer's parts, connectors, switches, controls and indicators.
- Read Chapter 2 to learn how to turn on the power, log in, log out and turn off the power safely.
- Read Chapter 3 to learn about the human interfaces that come with your system. This chapter will help you decide if you wish to use the HP Visual User Environment or an HP-UX shell to control your computer. This chapter also contains a guide to the use of the Boot Console User Interface, a program that allows you to change your system's configuration and behavior.
- Read Chapter 4 to learn how to protect your computer's most precious resource—its file system.
- Read Chapter 5 to learn how to add, replace, or remove memory and internal peripheral devices.
- Read Chapter 6 to learn how to diagnose hardware problems and to learn when and how to ask for assistance from your designated service representative

Audience

This guide is intended for use by service personnel and owners of HP Apollo 9000 Model 750 computers.

Read Me **Documents**

Please refer to the release documents you received with your system. These documents have titles that begin with the phrase “*Read Me.*” In these documents you will find information that may not have been included in this guide at the time of its publication.

Problems, Questions, and Suggestions

We appreciate comments from the people who use our computer systems. Use the *Reader Response Card* contained in this guide to submit comments about the guide.

Getting Help

You may need assistance from time to time. In this manual, the person who provides help is called the **designated service representative**. Check with the appropriate party (your purchasing department, for example) to find out where to request service.

Typeface Conventions

Unless otherwise noted in the text, this guide uses the following typeface conventions.

term	Marks the first appearance of a word and phrase that is used as terminology. Terms are explained immediately or defined further in a glossary. Example: The practice of copying files onto other media for safe storage is called backup .
Menu Item	The label of a menu item. Example: Select Network Configuration Tasks to continue.
computer output	Indicates one of the following: <ul style="list-style-type: none">■ Text output from a computer system, usually appearing on a terminal screen. Example: Console login:■ The literal name of software elements, such as files and programs. For example: “The <code>/etc/config</code> program ... ”
user input	Text that is to be typed into a computer system by a user. Example: \$ pwd
<i>variable name</i>	A variable whose value must be supplied by the user. Example: <code>cp</code> is a command entered by the user, and <i>filename1</i> and <i>filename2</i> represent the names of the arguments to the command: \$ cp filename1 filename2
<i>emphasized text</i>	A point of emphasis. Example: <i>Back up all files before proceeding further.</i>
Keycap	The character(s) printed on a keycap. Example: Return
Function Key	This indicates the label of a function key as it appears at the bottom of a terminal screen or window. Example: PERFORM TASK

Emissions Regulations

Federal Communications Commission (FCC)

The Federal Communications Commission of the U.S. government regulates the radio frequency energy emanated by computing devices through published regulations. These regulations specify the limits of radio frequency emission to protect radio and television reception. All HP Apollo nodes and peripherals have been tested and comply with these limits. The FCC regulations also require that computing devices used in the U.S. display the agency's label and that the related documentation include the following statement.

WARNING: This equipment generates, uses, and may emit radio frequency energy and, if not installed and used in accordance with these instructions, may cause interference to radio communications. It has been tested and found to comply with the limits for a Class A computing device pursuant to Subpart J of Part 15 of FCC Rules, which are designed to provide reasonable protection against such interference when operated in a commercial environment. Operation of this equipment in a residential area is likely to cause interference, in which case the user at his own expense will be required to take whatever measures may be required to correct the interference.

Compliance to these regulations requires the use of shielded cables.

Canadian Department of Communications (DOC)

This digital apparatus does not exceed the Class A limits for radio noise emissions from digital apparatus as set out in the Radio Interference Requirements of the Canadian Department of Communications.

Compliance to these regulations requires the use of shielded cables.

Verband Deutscher Elektrotechniker (VDE)

Herstellerbescheinigung

Hiermit wird bescheinigt, daß dieses Gerät in Übereinstimmung mit den Bestimmungen der Postverfügung 1046/84 funkentstört ist. Der Deutschen Bundespost wurde das Inverkehrbringen dieses Gerätes angezeigt und die Berechtigung zur Überprüfung der Serie auf Einhaltung der Bestimmungen eingeräumt.

Die Einhaltung dieser Grenzwerte schreibt den Gebrauch abgeschirmter Kabel vor.

VCCI Class 1 ITE Equipment

この装置は、第一種情報装置（商工業地域において使用されるべき情報装置）で商工業地域での電波障害防止を目的とした情報処理装置等電波障害自主規制協議会（VCCI）基準に適合しております。

従って、住宅地域またはその隣接した地域で使用すると、ラジオ、テレビジョン受信機等に受信障害を与えることがあります。

取扱説明書に従って正しい取り扱いをして下さい。

VCCI基準に適合する為に、シールドされたケーブルをご使用下さい。

Emissions Regulations Compliance

Any third-party I/O device installed in HP Apollo system(s) must be in accordance with the requirements set forth in the preceding Emissions Regulations statements. In the event that a third-party noncompliant I/O device is installed, the customer assumes all responsibility and liability arising therefrom.

Compliance to these regulations requires the use of shielded cables.

1

Your HP Apollo 9000 Model 750 Computer

This chapter provides an introduction to your HP Apollo 9000 Model 750 computer and its components. It describes the following:

- The locations of the system unit's switches and LED indicators
- How to interpret the LED indicators
- The mass storage device bays
- The parts of the rear of the system unit, including:
 - The system bulkhead and its connectors
 - The EISA card faceplate(s)
 - The graphic device bulkhead(s)
 - The power supply bulkhead

The System Unit

The **system unit** contains the computer system itself. The front of the central section contains the disk drive bays. The rear of the central section holds the system card and graphic device cards. The “shoulder” section to the right of the central section contains the EISA (Extended Industry Standard Architecture) card bay and the cooling fans. At the bottom of the entire unit is the power supply.

The system unit is intended for desktop placement.

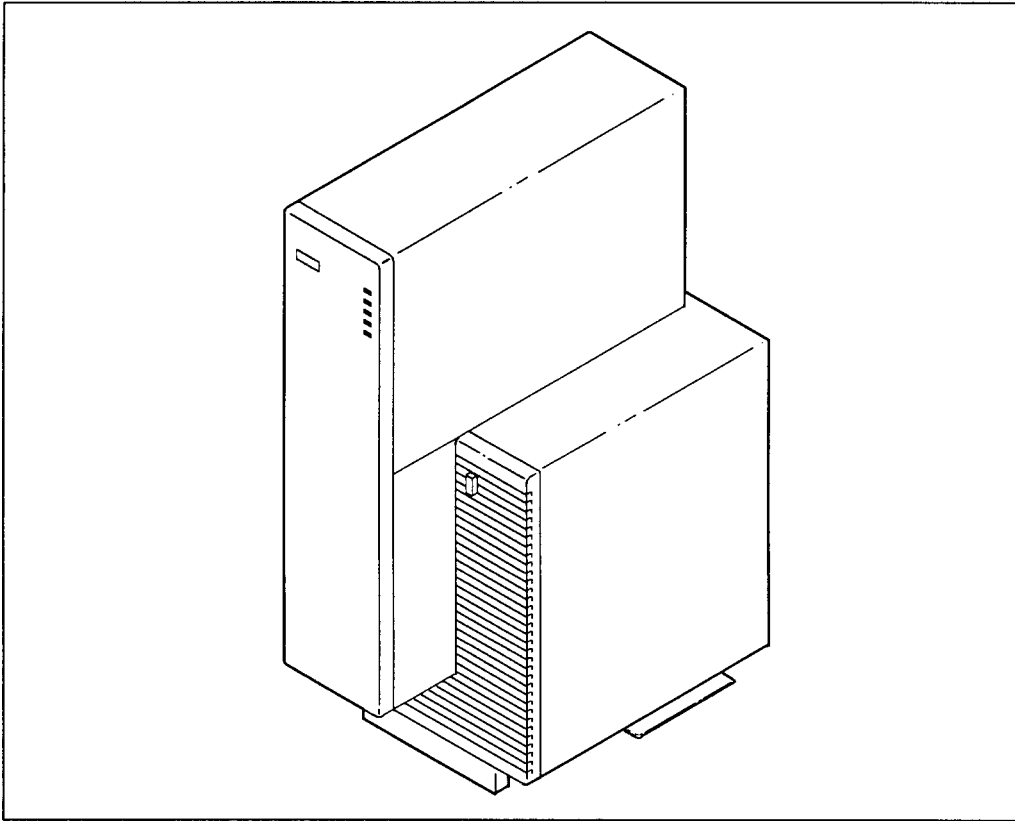

LG200193_001

Figure 1-1. The System Unit

1-2 Your HP Apollo 9000 Model 750 Computer

The Power On/Standby Switch

The switch that you use to turn on your HP Apollo 9000 Model 750 is located on the in the front of the system unit's right "shoulder." (See Figure 1-2.) This switch is actually a **power on/standby switch**. It is *not* the same as a power switch.

When you attach the power cable to the connector on the power supply and plug that cable into a power source, electric power is available from the power supply. When you turn on the power on/standby switch, that electrical power is distributed to the rest of the system unit.

Warning **Do *not* assume that all power to the computer is off just because the power on/standby switch has been turned off.**

To completely remove power from you computer, unplug the power cable from the power outlet and disconnect that cable from the power supply.

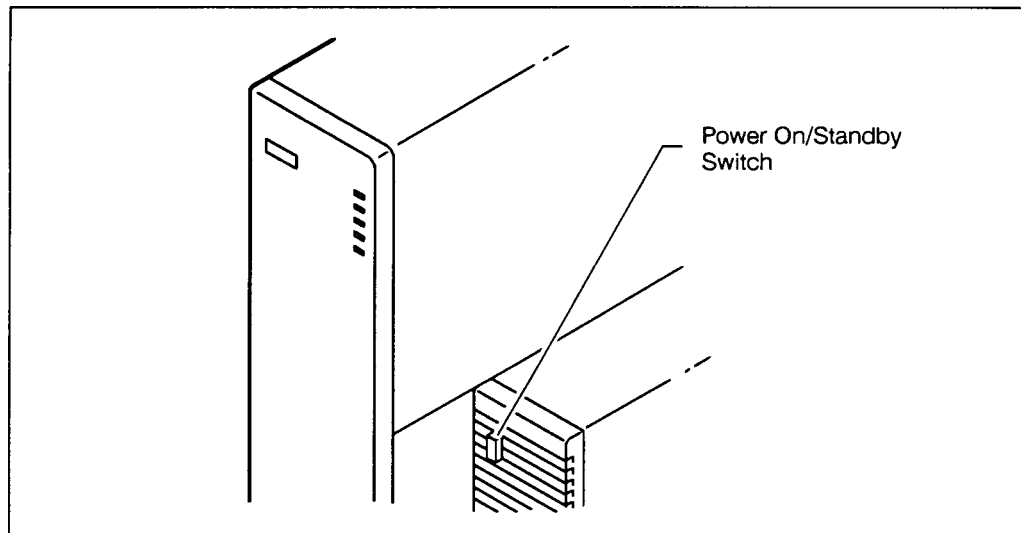





LG200193_002

Figure 1-2. Location of the Power On/Standby Switch

Understanding the LEDs

In the front of the system unit's center section is a hinged cover. When the cover is closed, five LEDs can be viewed through small "windows". Beside each window is a symbol indicating the meaning associated with the activity of each LED. Table 1-1 describes the activity of the lights when the HP-UX operating system is running on your computer.

Table 1-1. LED Symbols and Their Meanings

Symbol	LED Activity	Meaning
	On/Off	Power on/standby
	Flashing	Transmitting to LAN
	Flashing	Receiving from LAN
	Flashing	Disk activity
	Slow flash	System "heartbeat"

Note If you have been working on your system successfully, and the "heartbeat" LED remains off or on for a long period of time, it may mean that your system is "hung" (incapable of further processing). See Chapter 6 for suggestions on how to deal with this condition.

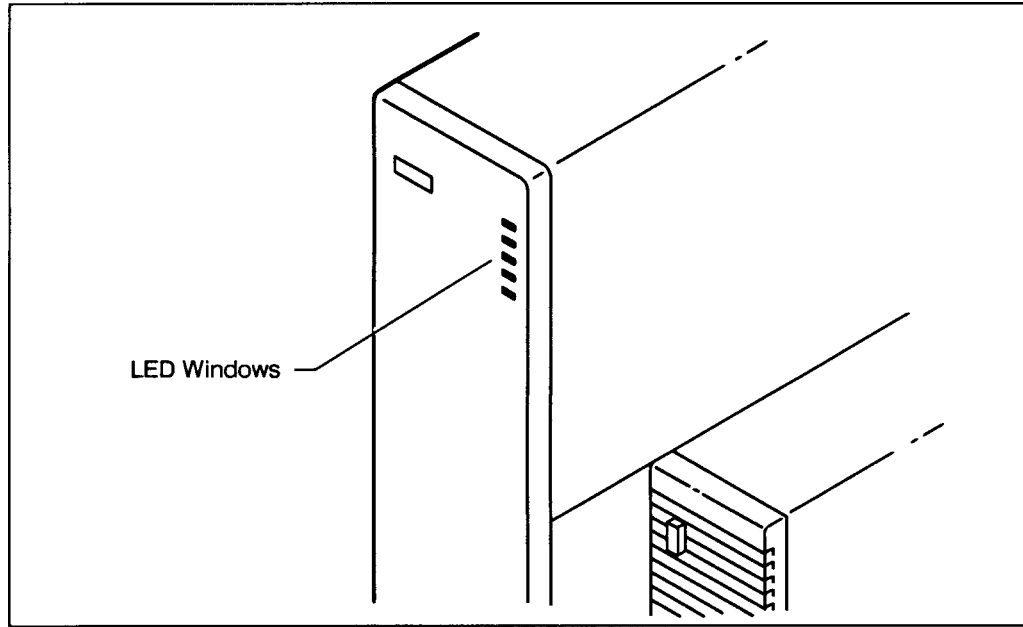

LG200193_003

Figure 1-3. LED Windows

Note

It takes a substantial amount of time (2—5 minutes) for your computer to start the HP-UX operating system. During this time, the behavior of these LED indicators (and the others hidden behind the cover) is not controlled by HP-UX. Do not interpret the behavior of the LEDs as illustrated by Table 1-1 until *after* HP-UX has finished booting.

The Back of the System Unit

In back of the system unit are connectors you can use to attach peripherals to your computer. The connectors are mounted on **bulkheads**: metal panels that cover portions of the rear of the computer. You can get access to most of the internal parts of your computer by removing some of these bulkheads. You will find descriptions of these internal parts in Chapter 5.

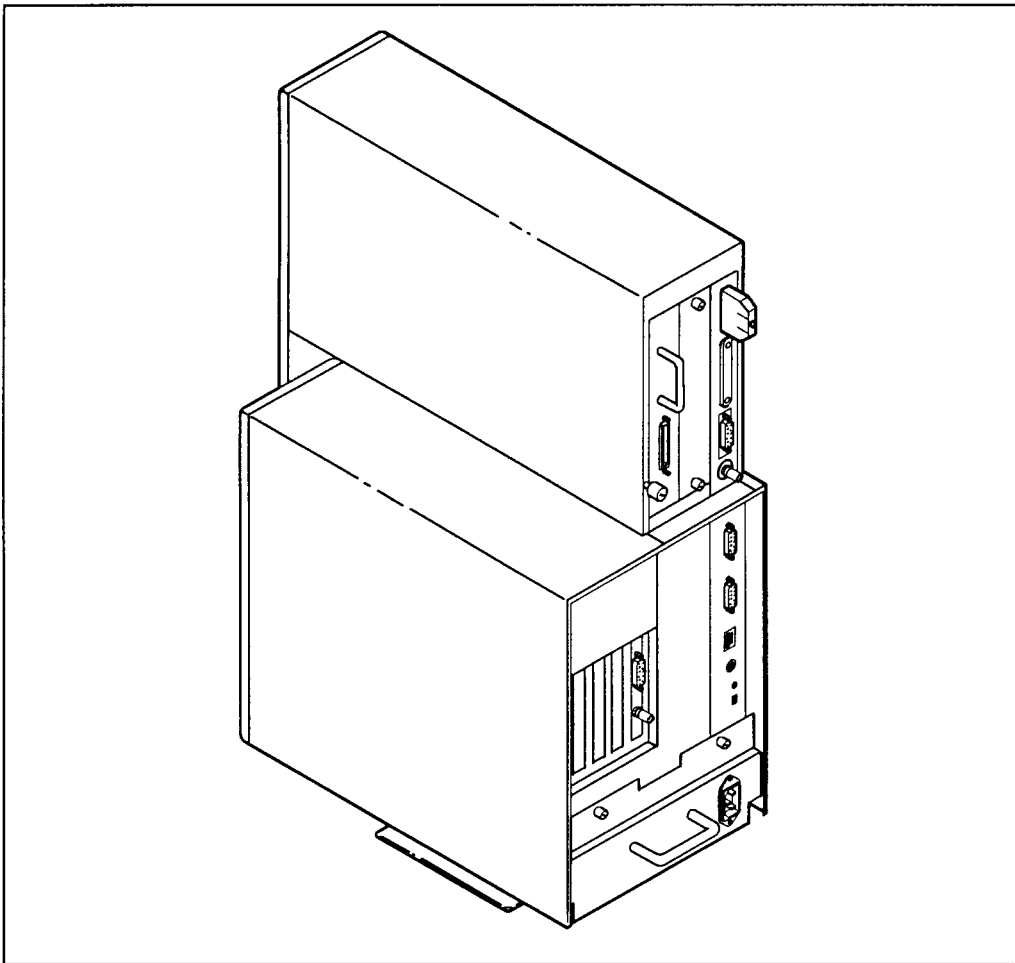

LG200193_004

Figure 1-4. The Back of the System Unit

The System Bulkhead

The system bulkhead is the rightmost and tallest of the bulkheads in the back of the system. (See Figure 1-4.) The I/O connectors and switches on this bulkhead are listed in Table 1-2 and illustrated in Figure 1-5.

Table 1-2.

I/O Connector or Switch	Use
SCSI	Used to attach external devices to the builtin SCSI (Small Computer Systems Interface) controller.
HP-HIL	Used to connect HP-HIL (Human Interface Link) devices to the system. The keyboard is an HP-HIL device.
Parallel	Used to connect external devices to the builtin parallel interface. Many printers have parallel interfaces which may be used with this connector.
Thin LAN	Used to attach the system to an Ethernet LAN (Local Area Network) that uses a BNC-type connector. Either this connector <i>or</i> the AUI connector may be used.
AUI	Used to attach the system to an Ethernet LAN (Local Area Network) that requires an external MAU (Medium Access Unit). Either this connector <i>or</i> the Thin LAN connector may be used.
RS-232	Each of these connectors may be used to connect external devices to the builtin serial interfaces. Most printers and modems can use these connectors.
Audio	Used to drive an external speaker or other audio device.
Reset switch	Restarts the computer by resetting the operating system.
Service/Normal switch	Used only during manufacturing. You will not need to use this switch.

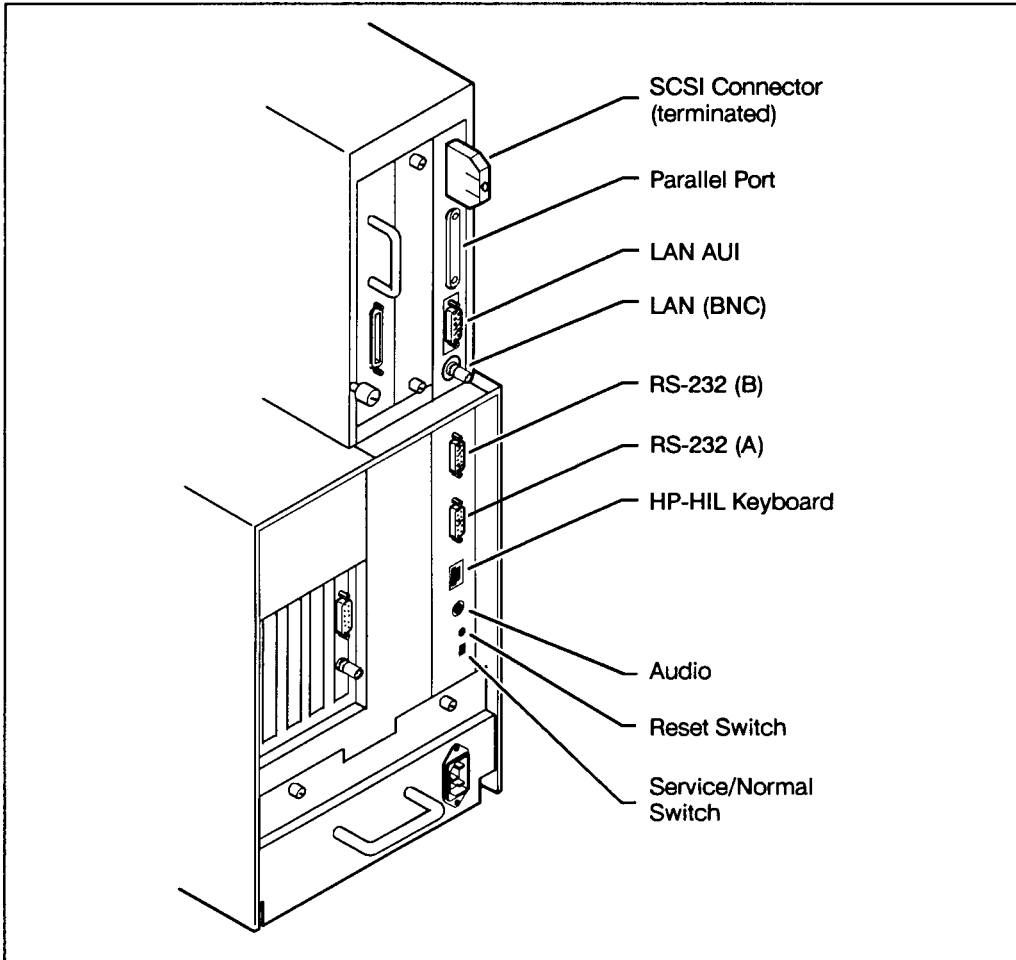

LG200193_005

Figure 1-5. Connectors Mounted on the System Bulkhead

1-8 Your HP Apollo 9000 Model 750 Computer

The Power Supply Bulkhead

This covers the power supply. It has a plug connector for the power cord. The power supply bulkhead is below the other bulkheads at the bottom of the system unit as you view it from the rear. See Figure 1-6.

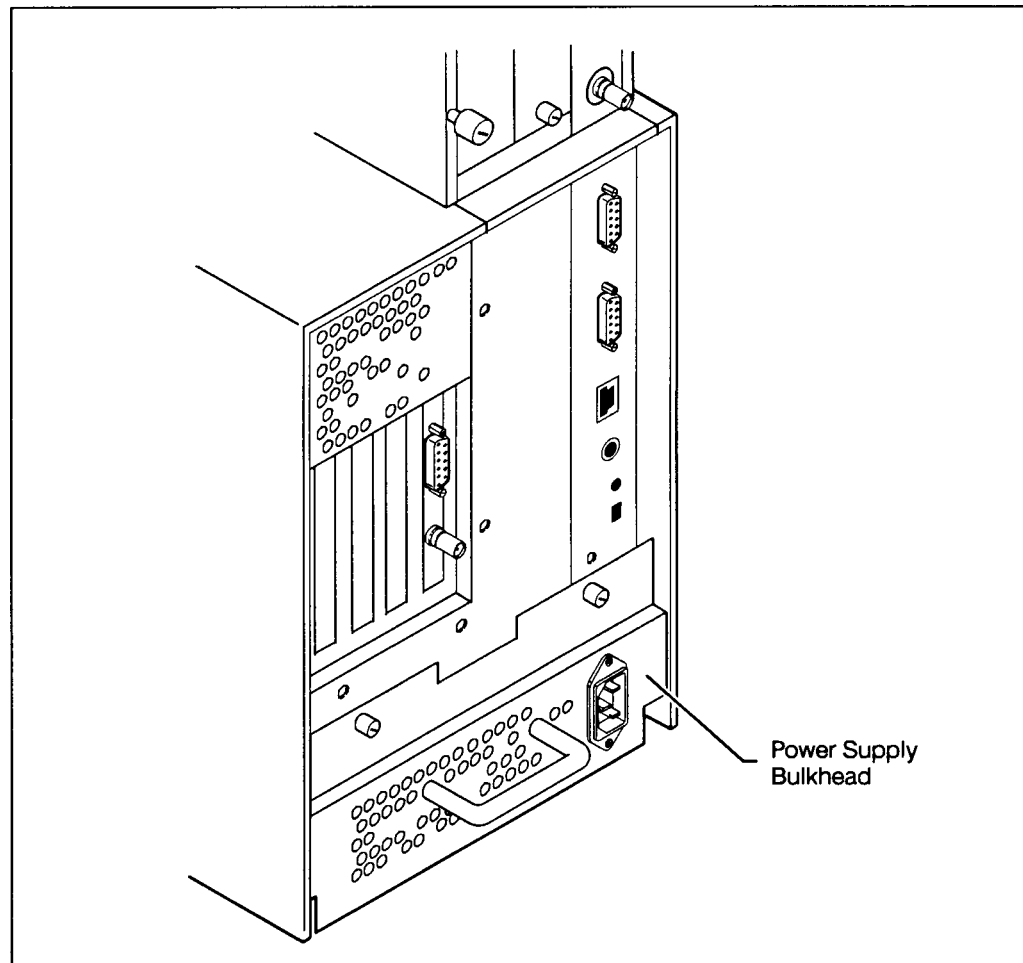

LG200193_007

Figure 1-6. The Power Supply Bulkhead

Graphic Device Bulkheads

If your computer system includes a bitmapped display, you will find the bulkhead for a graphic device to the left of the system bulkhead in the upper portion of the system unit. Your system may be equipped with two graphic display devices; if so, there may be two graphic device bulkheads.

If your system is a server, it will probably not have any graphic devices at this location.

You can have any of three types of graphic device in your computer:

- | | |
|------------------------|--|
| Color graphic card | This type of device has three BNC connectors (one for each for red, blue, and green). (See Figure 1-7). These are connected by a cable to three similar connectors on a color display monitor. |
| Grayscale graphic card | This type of device has one BNC connector. (See Figure 1-8). This is connected by a cable to a similar connector on a grayscale display monitor. |
| Graphic interface card | This type of device has a special connector. (See Figure 1-9.) It is connected to an external graphic processor, which in turn is connected to a video display monitor. |

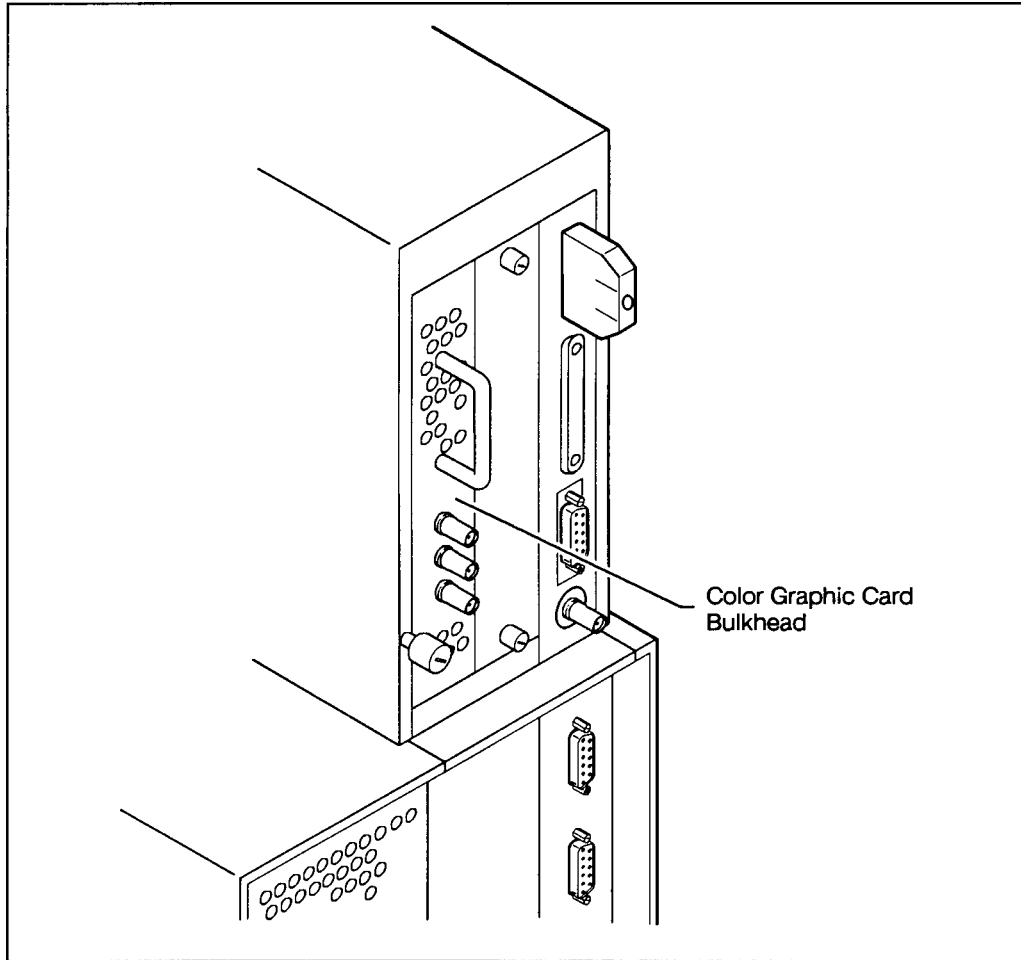

LG200193_008

Figure 1-7. Color Graphic Card Bulkhead

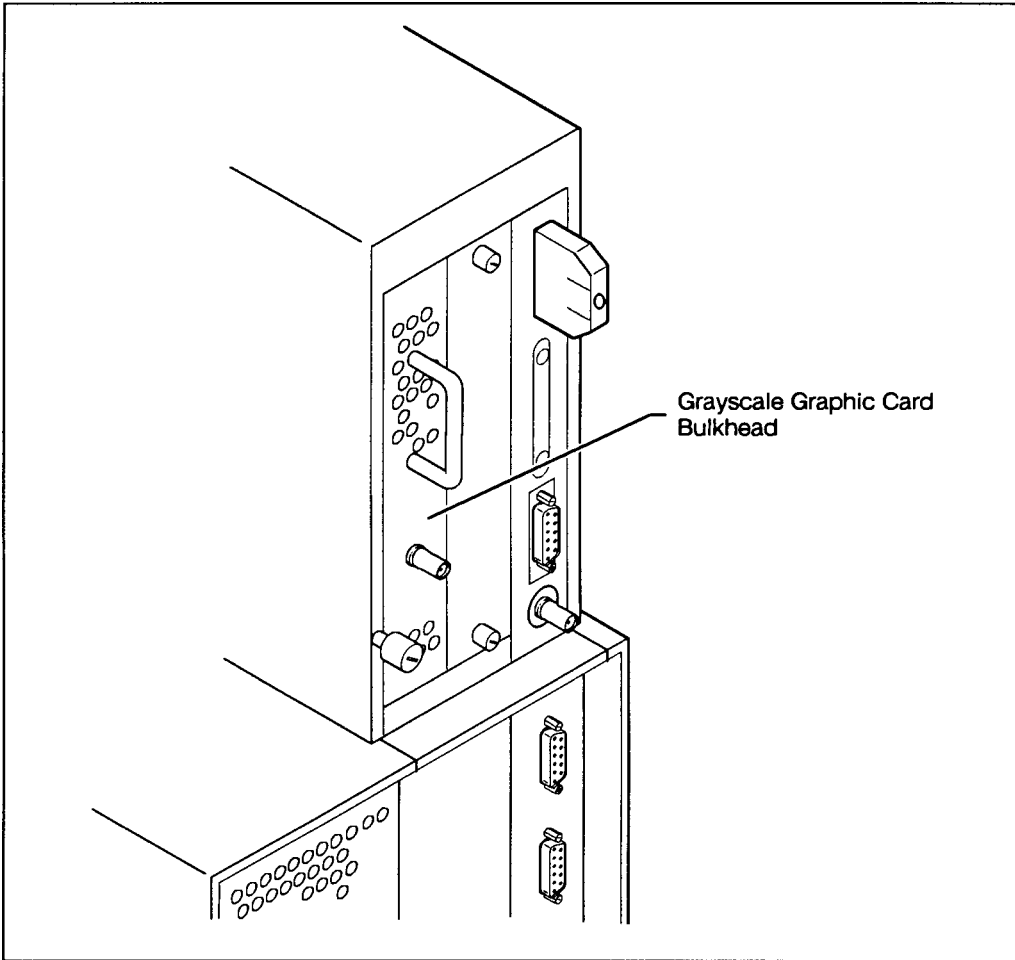

LG200193_009

Figure 1-8. Grayscale Graphic Card Bulkhead

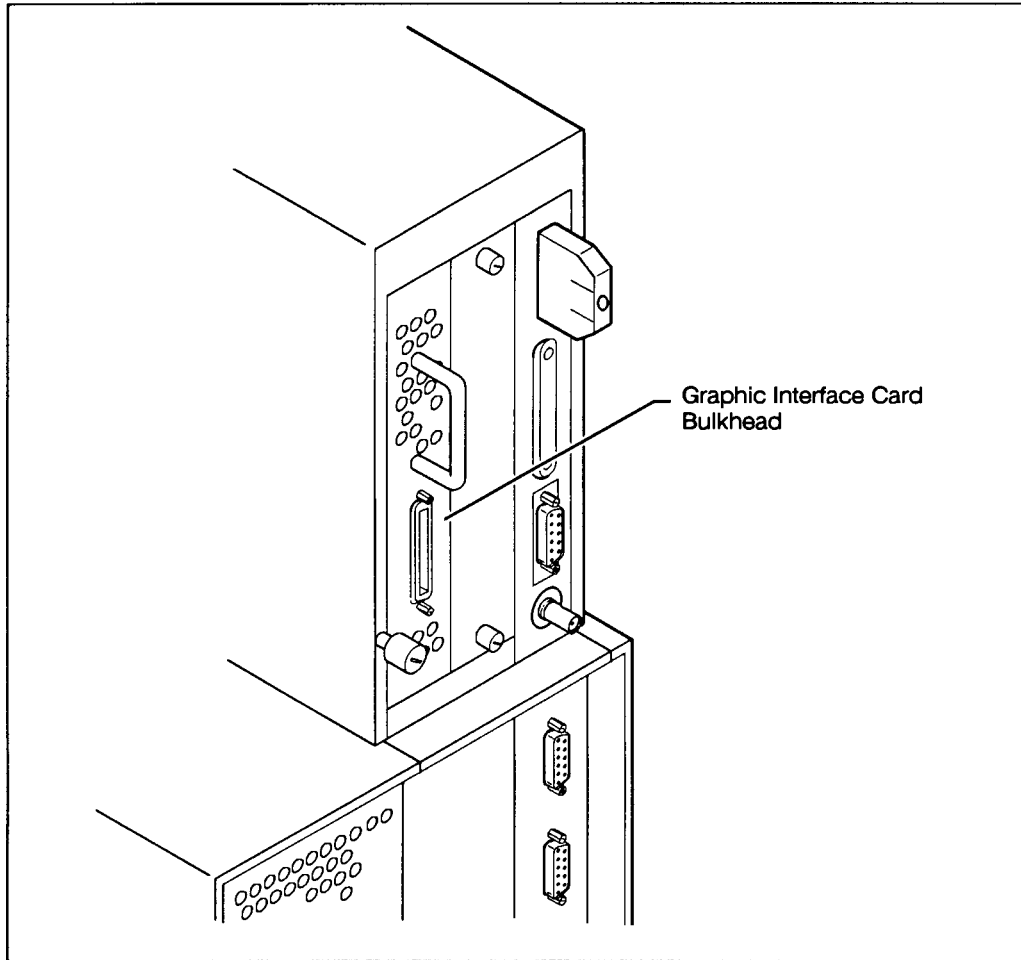

LG200193_010

Figure 1-9. Graphic Interface Card Bulkhead

Access to the EISA Card Faceplates

Your HP Apollo 9000 Model 750 includes four slots for EISA (Extended Industry Standard Architecture) circuit cards. These slots are in the EISA card bay above the power supply on the left side of the system unit (as viewed from the back). See Figure 1-10.

An EISA card has a **faceplate** upon which one or more connectors may be mounted. There are four vertical openings in the rear panel of the EISA card bay. These openings allow access to the faceplates of the cards. If your system contains no EISA cards, the openings should be covered with blank faceplates.

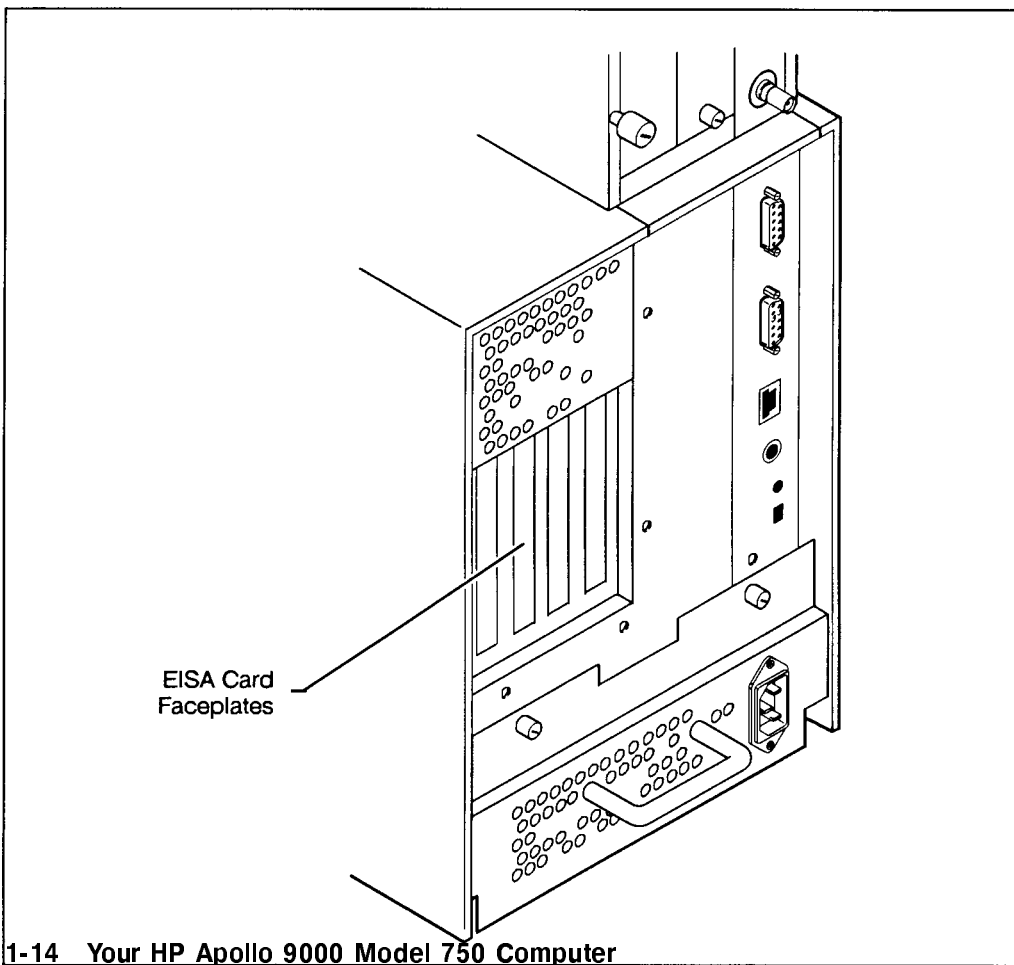

Figure 1-10. Openings for EISA Card Faceplates

The Monitor and Its Controls

The monitor is the bitmapped video display device for your HP Apollo 9000 Model 750 computer. It may be attached directly to a graphic card in your computer, or it may be attached to an external graphic processor. If your HP Apollo 9000 Model 750 is configured as a server, it will probably *not* have a monitor; see “Console Terminal”, below.

Before using your monitor, you should become familiar with the controls and indicators. For detailed information, see the installation instructions that are packaged with your monitor.

Console Terminal

If your HP Apollo 9000 Model 750 computer is configured as a server, it probably will not have a bitmapped display. Instead, it will use a **video display terminal** connected to Serial Port A on the I/O bulkhead.

Before using your monitor, you should become familiar with the controls and indicators. For details on the operation of your console terminal, see the installation and operating instructions that are packaged with the terminal.

— |

| —

— |

| —

Starting Up Your Computer

This chapter tells you how to boot HP-UX and get started with the HP Visual User Environment. It describes the following:

- How to boot (start up) the HP-UX operating system on your computer
- How to log in (start a work session) as the **root** user
- How to log out (end a work session)
- How to create a new user account for yourself
- How to shut down your computer and turn off the power safely

Are You Ready?

This chapter assumes the following:

- Your computer is equipped with a bitmapped display. If it is not, you will probably use a text terminal as your system console. Consult “About Shells” in Chapter 3 and *A Beginner’s Guide to HP-UX* for information about basic interaction with the **shell** (command-line interface). See *System Administration Tasks* manual for information on managing your system.
- Your computer hardware has been unpacked and installed (including computer, keyboard, monitor, and any external peripherals) according to the instructions in *Installation Guide for HP Apollo 9000 Model 750 Workstations and Servers*.
- If your computer is connected to a local area network, the physical connection to the network has been made.
- If your computer is a member of an HP-UX cluster, it has been added to the cluster according to the instructions in *Managing Clusters of HP 9000 Computers*.

- You know where your system unit's power on/standby switch is. Refer to Figure 1-2. You should also be able to locate the power switches for the monitor and the external graphic processor, if your system includes these components.
- The HP-UX system software is installed and ready to boot. This will be true in either of the following cases:
 - Your computer was delivered with the following software preinstalled on its disks:
 - The HP-UX Operating System, Release 8.05 (or later)
 - The X Window System, Version 11, Release 4 (or later)
 - The HP Visual User Environment (VUE)
 - You have installed HP-UX from tape according to the instructions in *Installing and Updating HP-UX*.

If your software is not yet installed, please install it before proceeding further.

Before Turning On the Power for the First Time

If you are turning on your computer for the first time, you will be asked for some information about your system. You should know the following things:

- The **system name** of your computer. This is sometimes called the **host name**. The system name should not exceed eight characters in length. Obtain a system name from your system administrator.
- The **time zone** where your computer is located.

If you are connecting your system to a local area network, you will also need to know this:

- The **internet protocol address** (or **IP address**) of your computer. This is a four-element code that uniquely identifies your computer among all those located on your network (or anyone else's). Obtain this address from your network administrator.

Have this information at hand when you turn on the power for the first time. Enter the information when your system requests it. If you do not have the information when prompted for it, the system will allow you to exit and restart the system at another time when you can have the information ready at hand.

2-2 Starting Up Your Computer

Booting HP-UX

When you turn on the power to your computer, it will **boot** the HP-UX operating system. The expression “boot” is short for “bootstrap;” the computer loads a sequence of programs, each enabling more of the system than the previous program. Thus the computer “pulls itself up by its own bootstraps.”

A computer’s **operating system** is a set of programs that controls the execution of other programs. HP-UX is a **multitasking** operating system because it allows your computer to run many programs simultaneously. HP-UX is also a **multiuser** system because it allows a number of different users to run programs at the same time.

Once HP-UX is running on your system, you must **log in** as a user. If you are accustomed to working on single-user personal computers, this may strike you as odd, especially if you are the only user of your machine. However, the process of user login is one of the ways that HP-UX prevents unauthorized persons from using your system. This is especially important if your system is attached to a network.

Turning On the Power

Turn on the power to the monitor and any external peripherals first. If necessary, wait for any external disk drives to come up to speed. (The installation documents that are supplied with the external drives will explain this.)

After the monitor and any other external devices have been turned on, turn on the computer.

HP-UX Starts Up

After about three minutes, many messages appear on your screen. These messages convey information about the various hardware and software subsystems that are being activated by the bootup process. Unless something is wrong with your system, you will not have to respond to any of these messages.

Logging In

- 1 After your computer has booted HP-UX, the login screen shown below appears.

This means your hardware installation was successful and HP-UX has booted. Your HP VUE has also loaded and started.

If this screen does not appear, see Chapter 6, or contact your designated service representative.

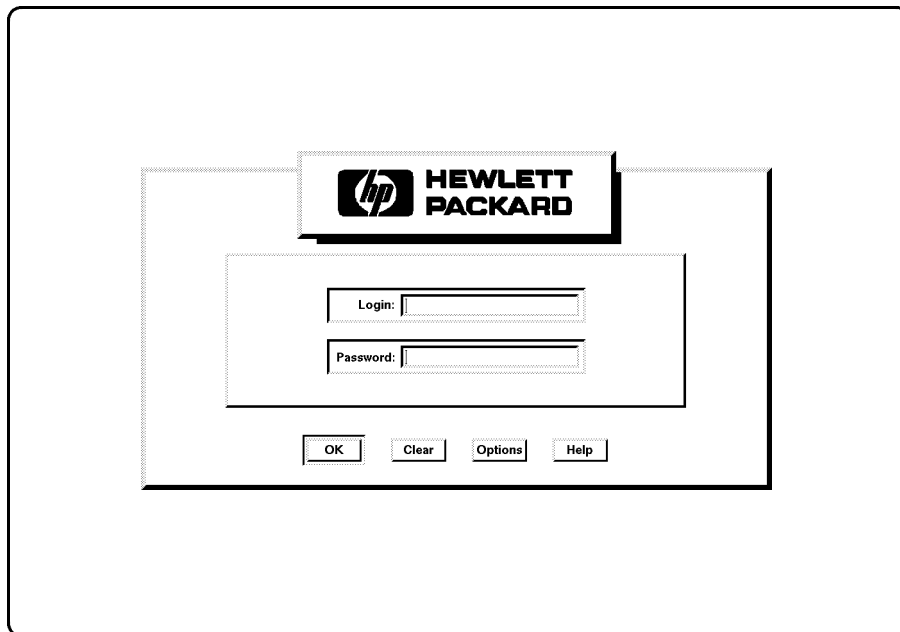

2 You must first login as **root**. To login as **root**, type:

```
root 
```

If you have given your computer a hostname other than **unknown**, skip to step 4. Otherwise, go on to step 3.

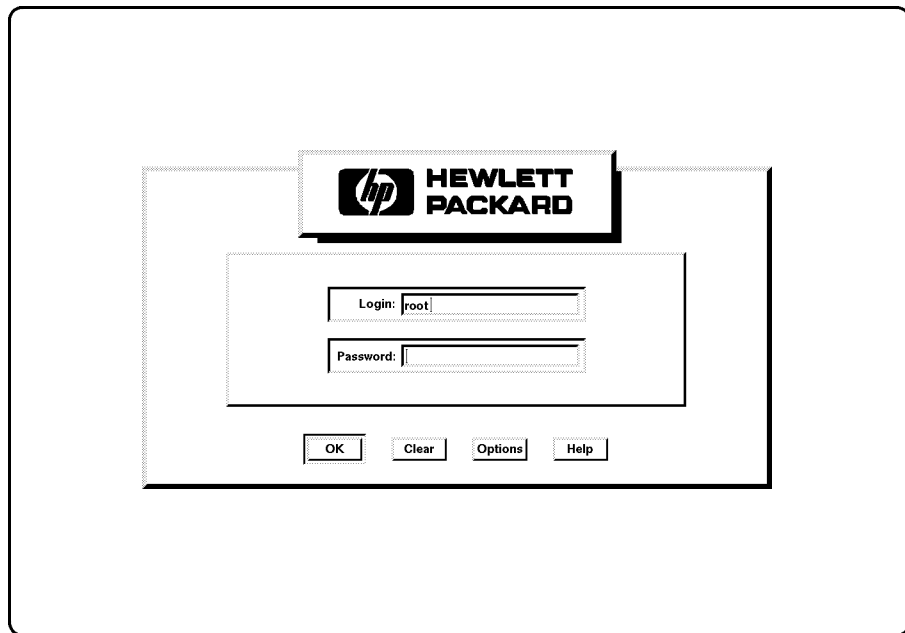

- 3** If a window appears over your login screen cautioning you about your computer's hostname being **unknown**, you may continue and start HP VUE. Move your mouse to put the pointer on the **Start HP VUE** screen button, then click the left mouse button once.

Caution

- Later, you should use the `/etc/setparms` program to enter a host name for your system.
 - You should not click on the **No Windows** screen button until you have learned how to read and edit files.
-

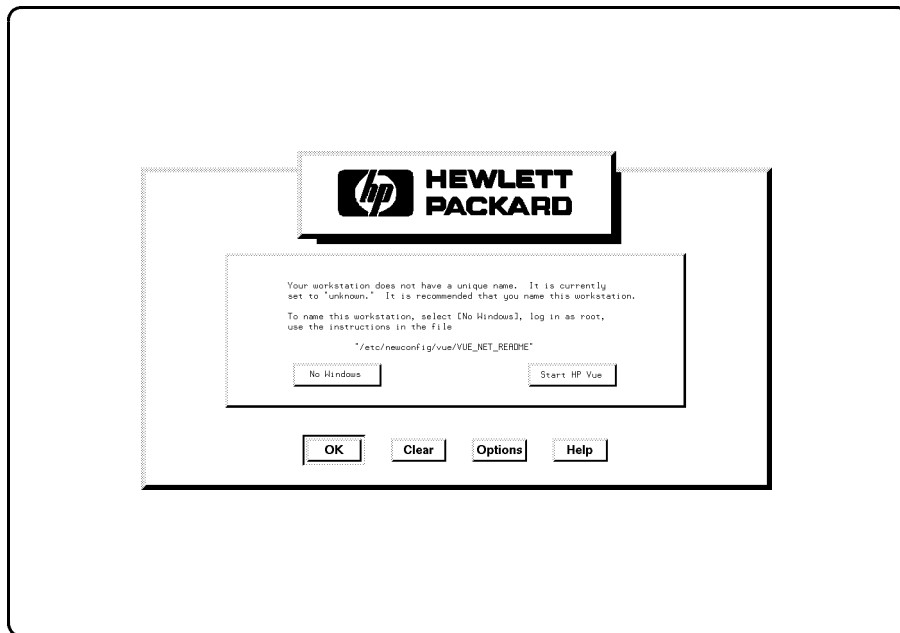

4 The copyright screen shown below appears.

Your HP VUE **workspace** (the screen environment in which you interact with HP-UX) appears in about one minute.

Note

The windows displayed on your screen may not be exactly like those shown in this manual.

Starting the
Hewlett-Packard
Visual User Environment

(c)Copyright 1983-1991 Hewlett-Packard Co.
(c)Copyright 1979, 1980, 1983, 1985-1990 The Regents of the Univ. of California
(c)Copyright 1980, 1984, 1986 AT&T Technologies.
(c)Copyright 1986, 1987, 1988 Sun Microsystems, Inc.
(c)Copyright 1985, 1986, 1988 Massachusetts Institute of Technology
(c)Copyright 1986 Digital Equipment Corp.
(c)Copyright 1990 Motorola, Inc. All Rights Reserved.

RESTRICTED RIGHTS LEGEND

Use, duplication, or disclosure by the Government is subject to restrictions as set forth in subparagraph (c) (1) (ii) of the Rights in Technical Data and Computer Software clause at DFAR 252.227-7013 and subparagraph (c) (2) of the Commercial Computer Software Restricted Rights clause at FAR 52.227-19.

HEWLETT-PACKARD COMPANY
3000 Hanover St.
Palo Alto, CA 94303

- 5 A screen similar to this one appears, with a **console icon**, two **file manager windows**, a window entitled “Fasten Your Seatbelt,” and the **workspace manager**. The workspace manager is also known as the **control panel**.

Move the mouse pointer into the file manager window for the `/usr/demos/bin` directory. It contains the **icons** (small pictures) for the demonstrations. To run a demonstration, move the mouse pointer over an icon, and press and release the left mouse button twice quickly. This is called “**double-clicking**.”

Place the pointer over the screen button labeled “Continue,” and “**click**” the left mouse button once by pressing and releasing it. This will close the “Fasten Your Seatbelt” window.

Close the file manager window for the demonstrations by double-clicking on its **window menu button**. Move the mouse pointer over the **minimize button** in the other file manager window and double-click on it. This will turn the window into a **file manager icon**. Move the mouse pointer over the console icon, and double-click on it.

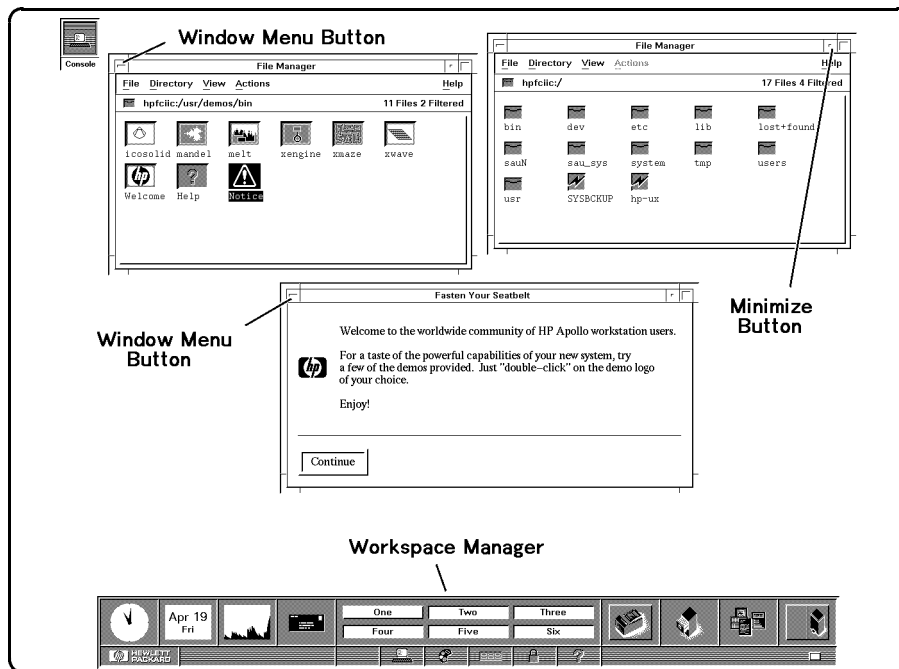

- 6 The console icon disappears and is replaced by the **console window**. This is a **terminal window**. It behaves just like any text terminal. You may type a command into it, and it will print the results of the command's execution.

For the moment, though, you will use another feature of the HP Visual User Environment: the Help System. Through interaction with the Help System, you may learn about HP VUE.

Move the pointer to the **help screen button**. It's along the bottom of the control panel, and it has a question mark ("?") on it. Click the left mouse button once.

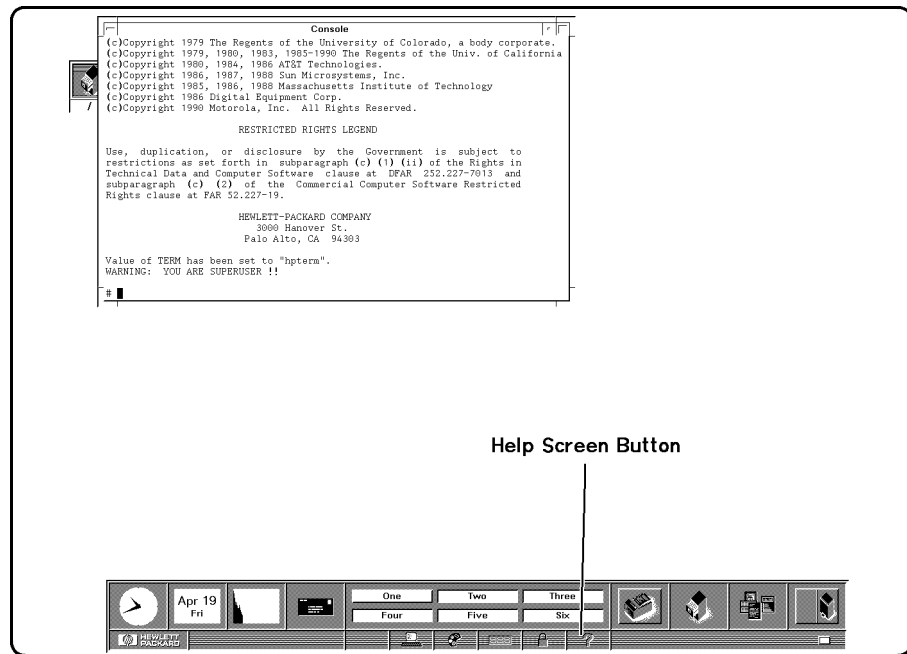

7 The Help Index window shown below appears.

Move the mouse pointer into the window and onto the line

A Tutorial for New Users

and click the left mouse button once to bring the next index into the window. Then click the left mouse button once on the **Viewer** screen button to see the help information.

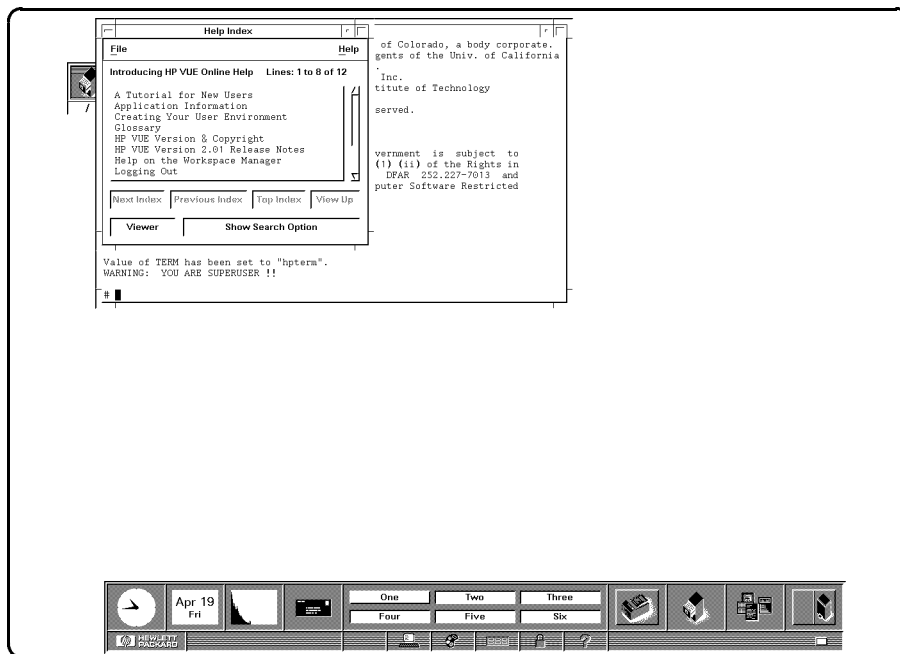

- 8** The first part of **A Tutorial for New Users** is displayed in the Help Viewer window. To see more of the text, you must use the scroll bar. You need not read all the information now. See *HP Visual Environment User's Guide* for information on using the scroll bar.

Close the Help Viewer window by moving the mouse pointer over the window menu button in the upper left-hand corner of the window and double-clicking the left mouse button.

Close the Help Index window in the same way. Turn the Console window into an icon by clicking on its minimize button.

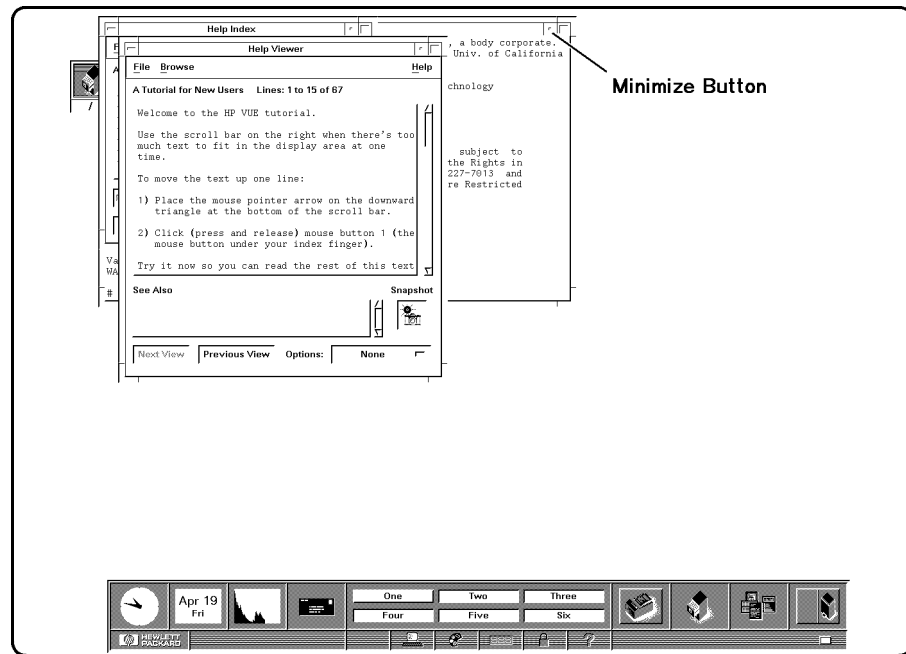

Logging Out

- 1 To logout, move your pointer onto the control panel's lower right-hand bar. This bar is called the **logout button**. Click the left mouse button once.

Notice that the **progress light** on the logout button begins to blink. This indicates that the logout process has begun.

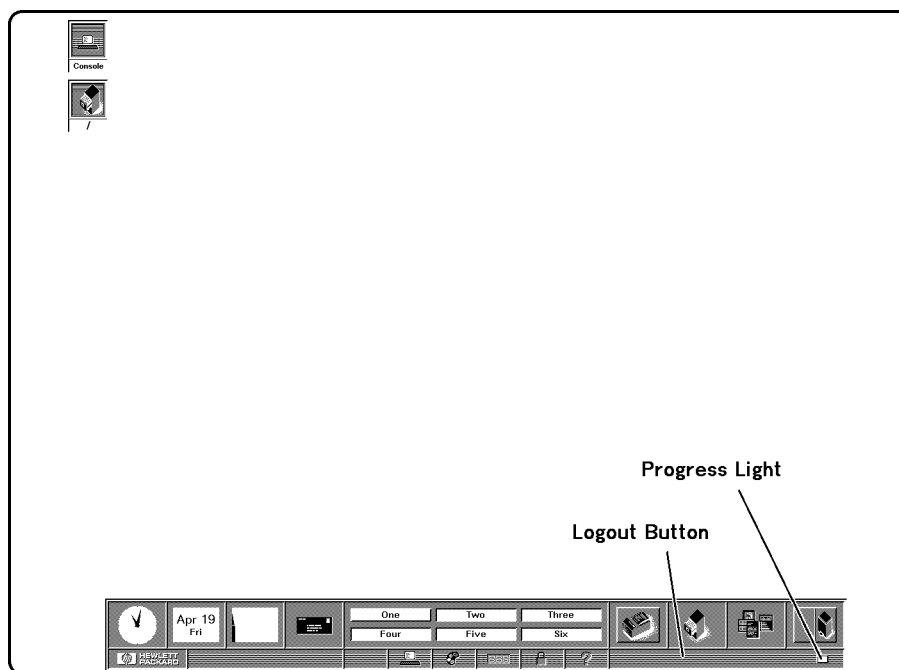

- 2 This confirmation box will appear. To confirm your logout, click on the screen button marked “OK.”

A short time later, the login screen will reappear.

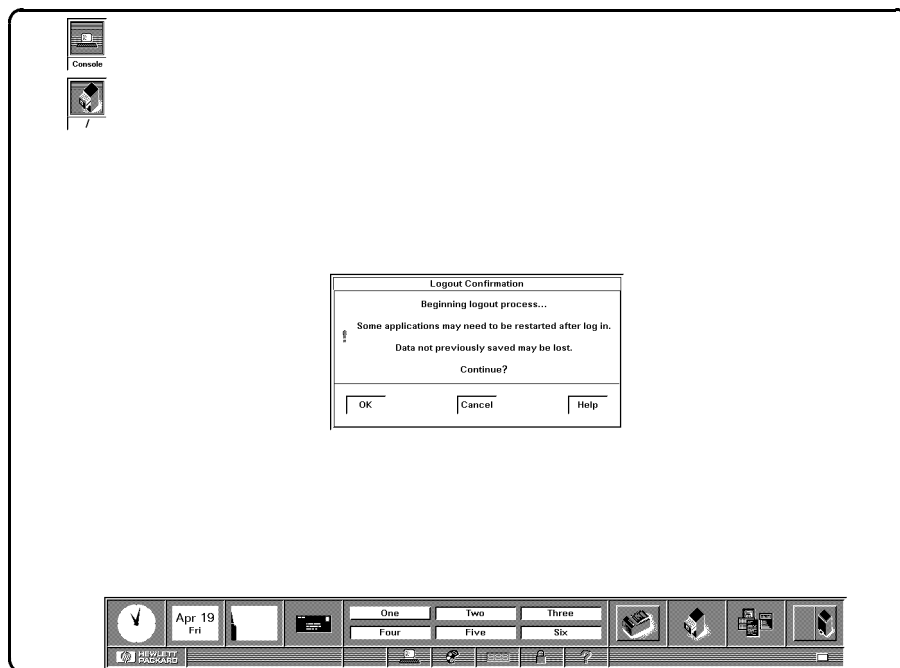

Caution

Do not turn off the power to your computer without first performing the shutdown procedures described in “Shutting Down Your Computer”. If you do not shut down your computer properly, you may damage the programs and data on your disk.

Creating a New User Account

- 1 To create a new user account that you will normally use, you must first login as `root`.

Caution `root` is a user account with special privileges and dangers. Only the system administrator should regularly login as `root`.

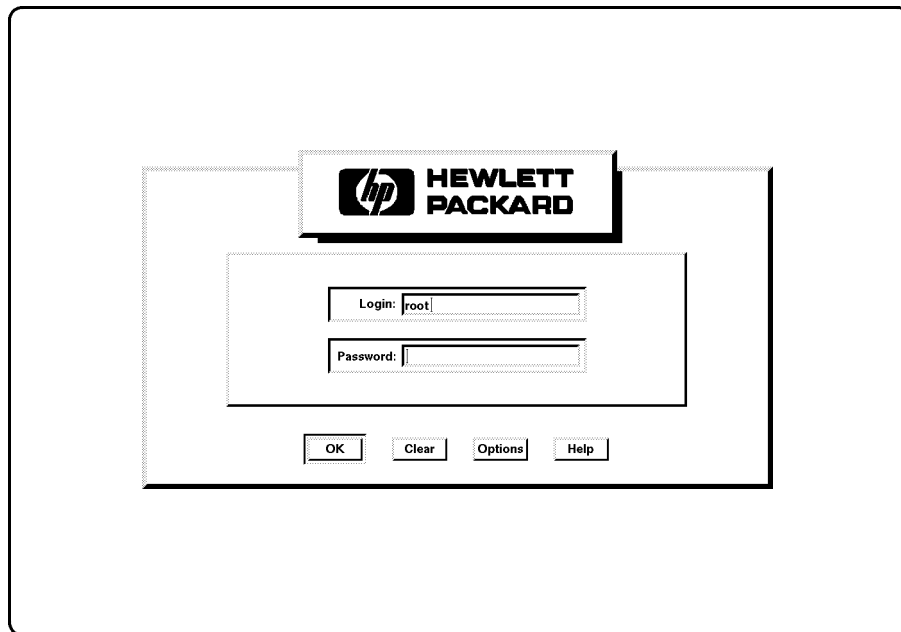

- 2 Activate the Help System by moving the pointer to the control panel's **help screen button** (on the bottom, marked with a “?”) and clicking the left mouse button once.

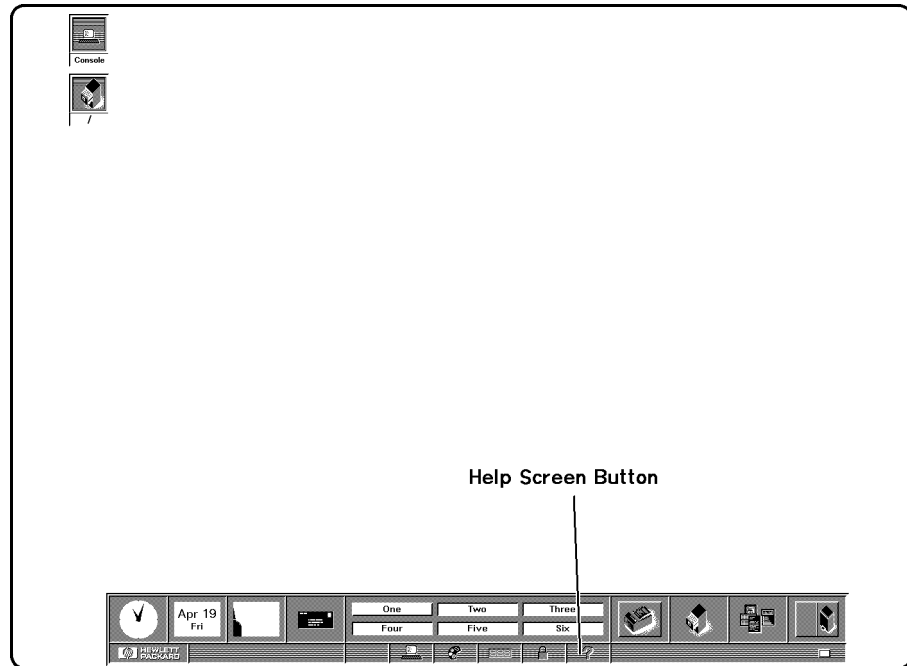

- 3 When the Help Index window appears, click on the **down arrow** in the scroll bar to move the text so that you can see the **System Administration Tasks** entry. Move your pointer onto this entry. Then click the left mouse button once.

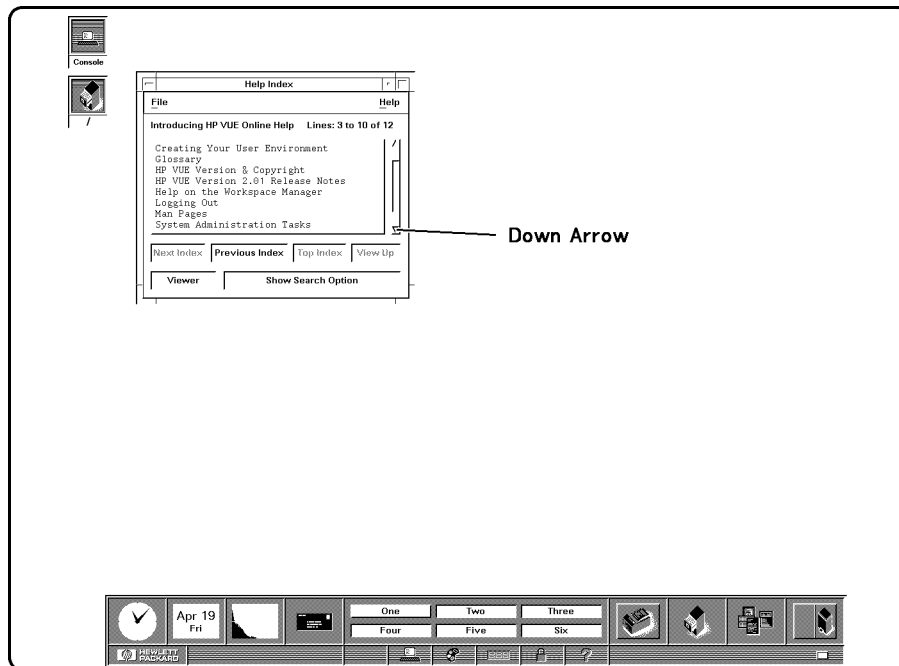

- 4 When the **System Administration Tasks** Help Topic window appears, select and click on

Creating a New User Account

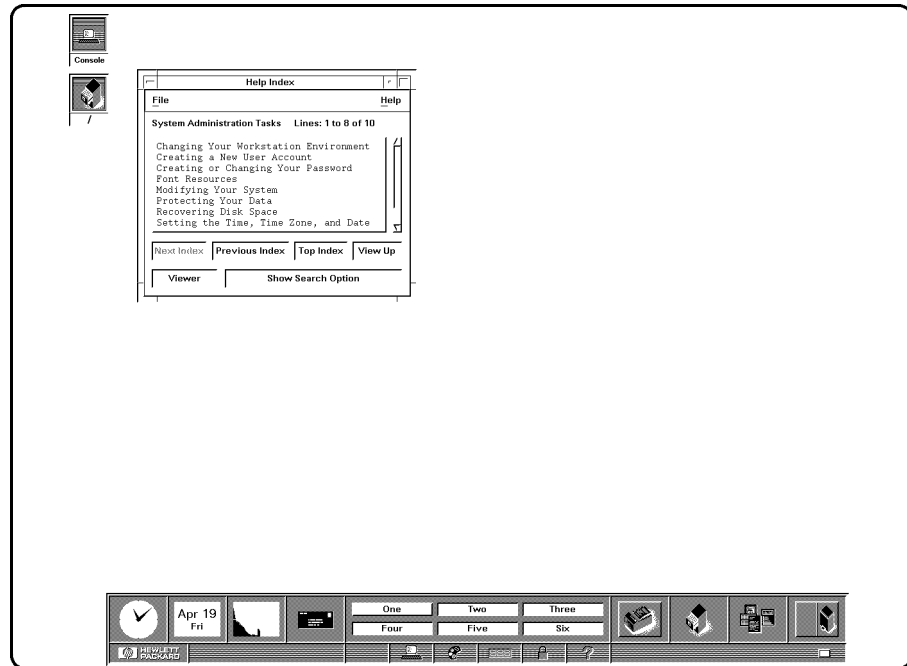

- 5 Read the instructions for creating a new user account. Click on the **down arrow** and **up arrow** in the scroll bar to scroll through the instructions.

When you have finished reading the instructions, click on the control panel's **application button**. That button has a few sheets of paper pictured on it.

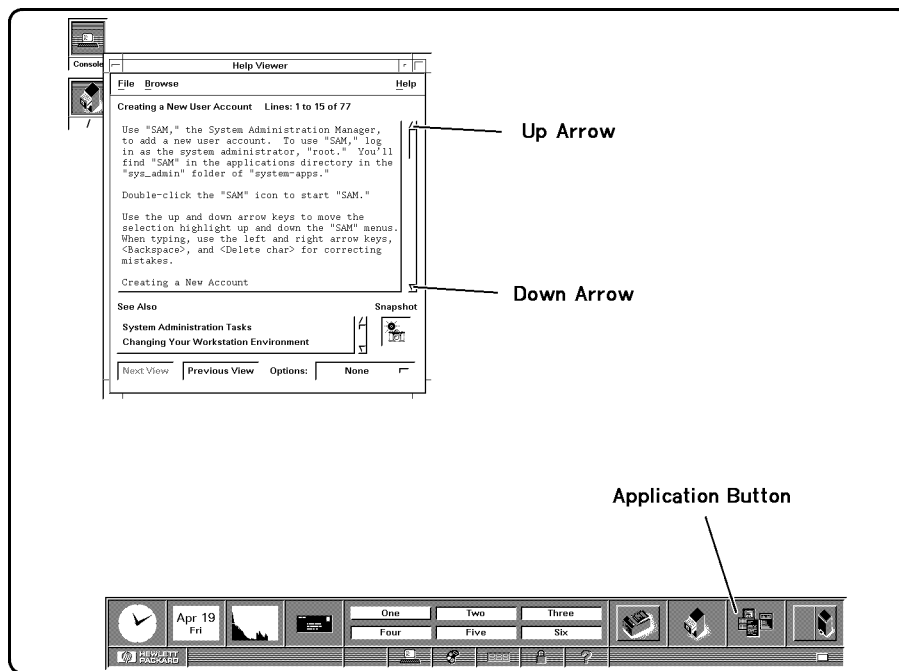

6 You will see a file manager window similar to this one.

To open the **system_apps** folder, move the pointer onto the **system_apps** folder icon, then double-click the left mouse button.

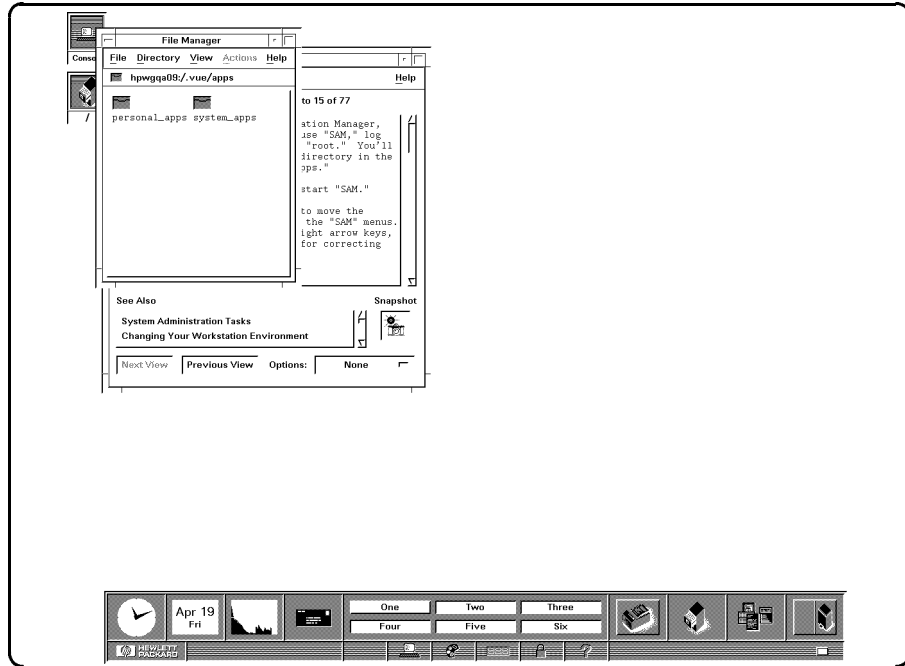

7 You will see a system applications window similar to this one.

Open the **sys_admin** folder by putting the pointer on it and double-clicking the left mouse button.

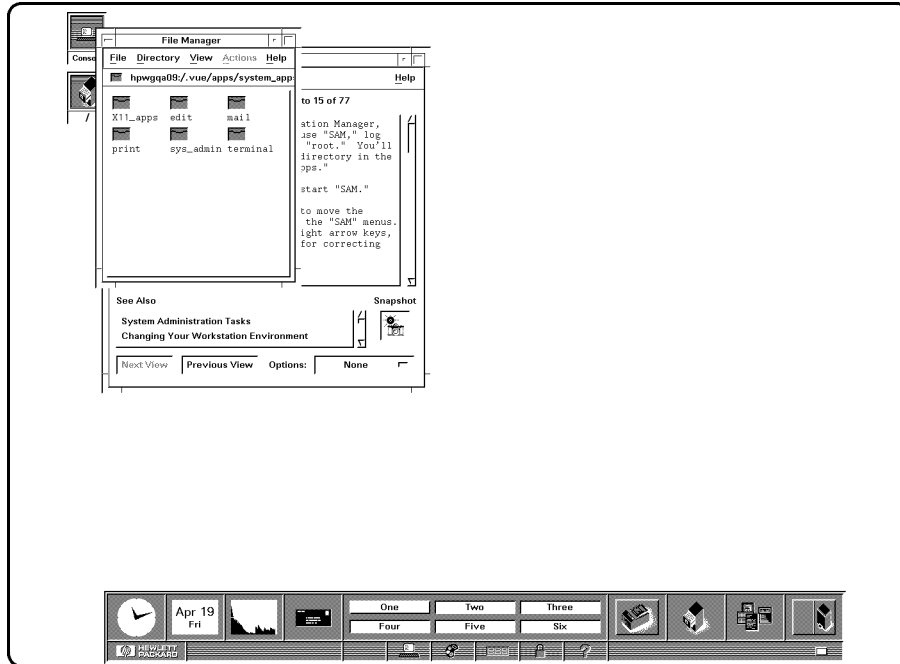

8 This system administration window appears.

Move your pointer onto the System Administration Manager (SAM) icon and double-click the left mouse button.

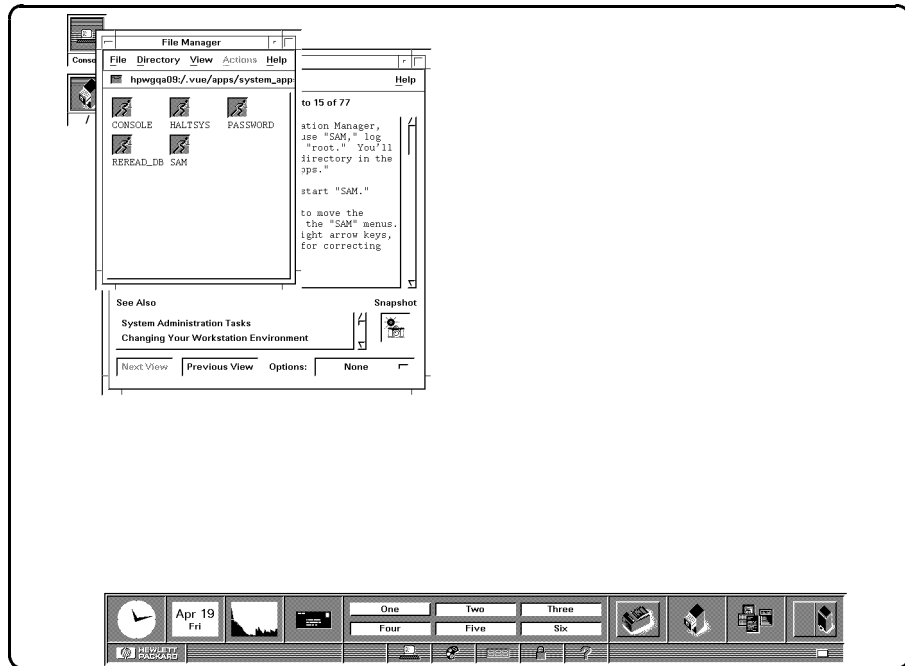

- 9 The System Administration Manager (SAM) is an application designed to run on text terminals. If you wish to move the highlight bar to another item, you must use the cursor keys. To press a softkey, you may either use the function keys on your keyboard or use the mouse to click on the softkeys in SAM's terminal window.

With this item highlighted,

`Users ->`

move the mouse pointer over the **Select Item** softkey and click the left mouse button once.

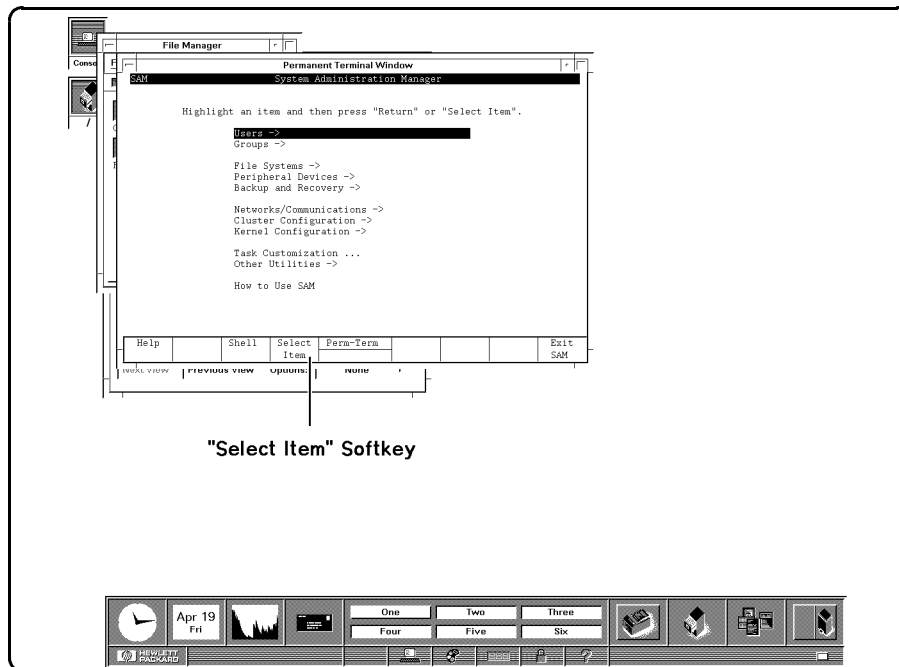

10 When this window appears, this line will be highlighted:

Add a New User Account to the System

Move the mouse pointer over the **Select Item** softkey and click the left mouse button once.

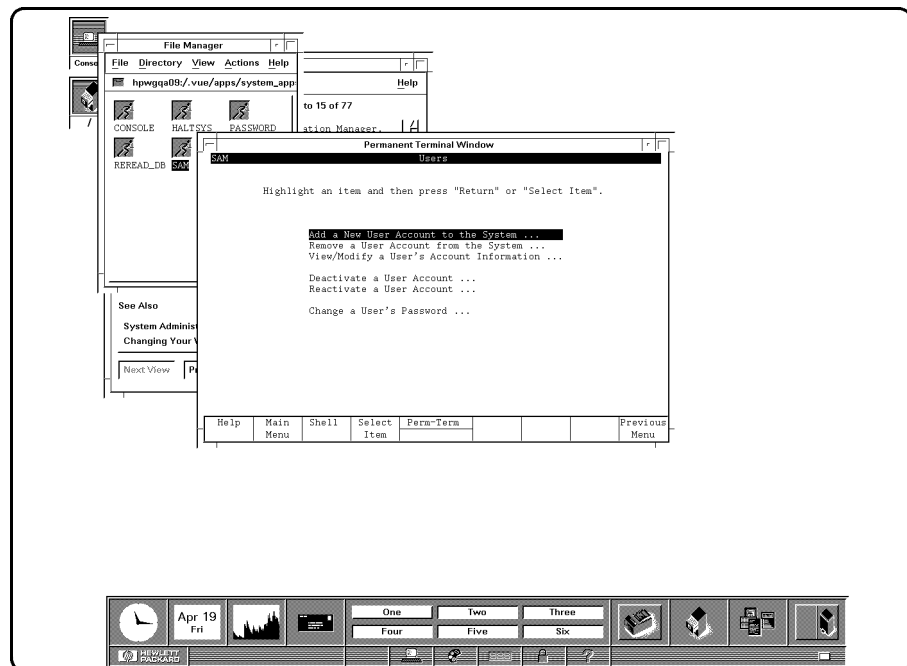

11 Type the login name you want to use for normal work, for example:

wizard

Note that some items are set to their default values. Normally, these need not be changed.

Click on the **Perform Task** softkey.

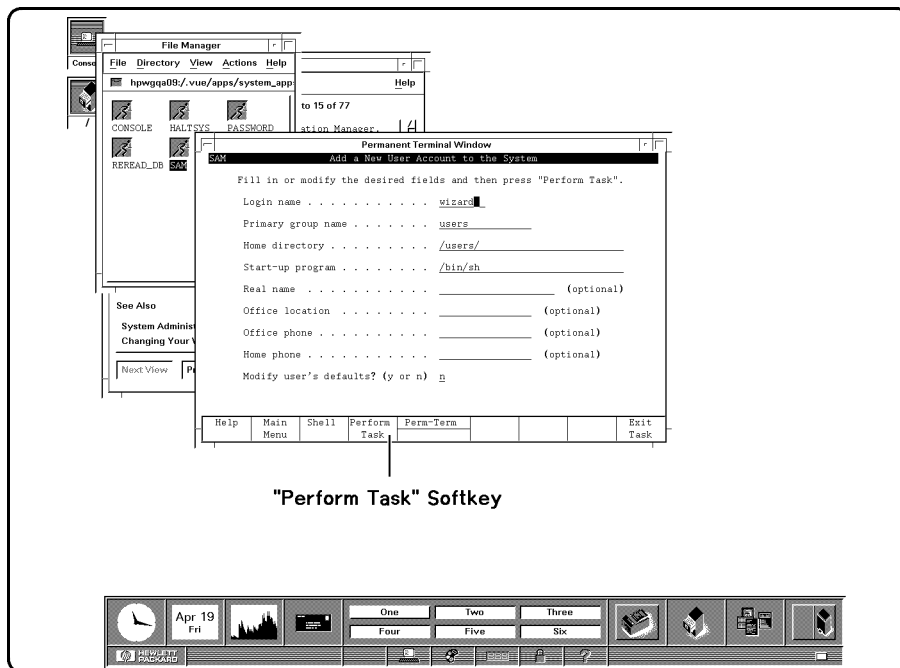

12 Type in the password for your new login account.

For example:

123four

then press the **Return** key or click on the **Done** softkey.

Caution *Remember your password!* If you forget your password for the system, you won't be able to log back in under the login name you have chosen.

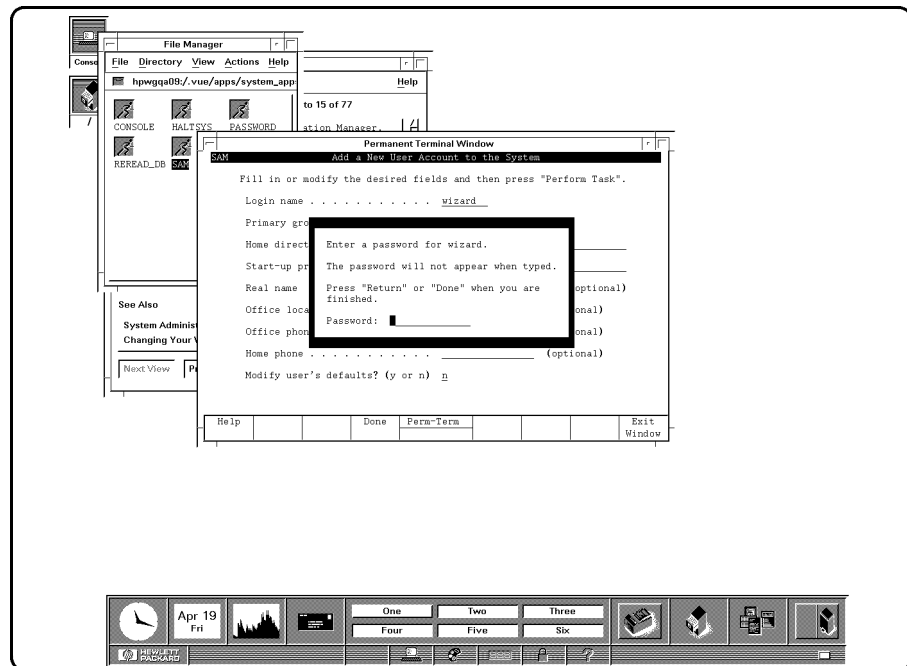

- 13** Reenter the password, then press **Return** or click on the **Done** softkey.

The new user will be added to the system while this message is displayed:

Adding user *user_name*...

You should also create a password for **root**. Refer to Appendix A of the *HP Visual User Environment User's Guide*.

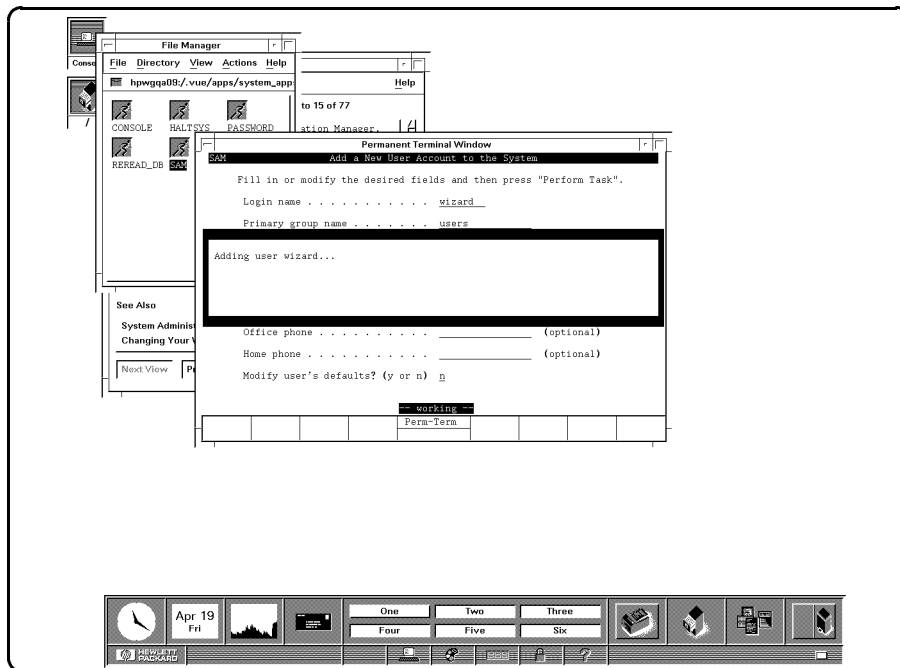

- 14** After the new user has been added to the system, press the keyboard space bar to get a blank form.

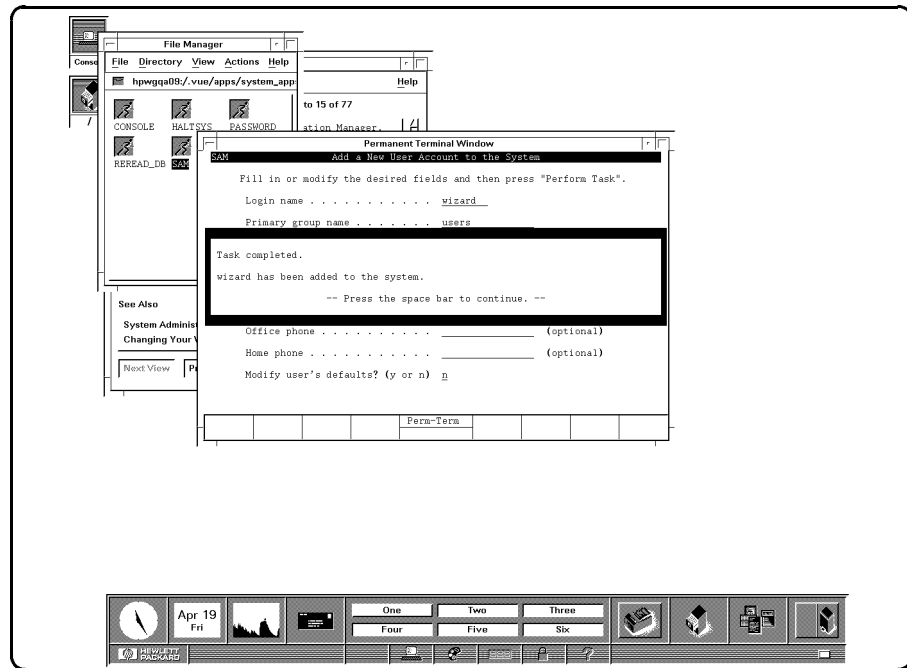

15 Click on the **Main Menu** softkey.

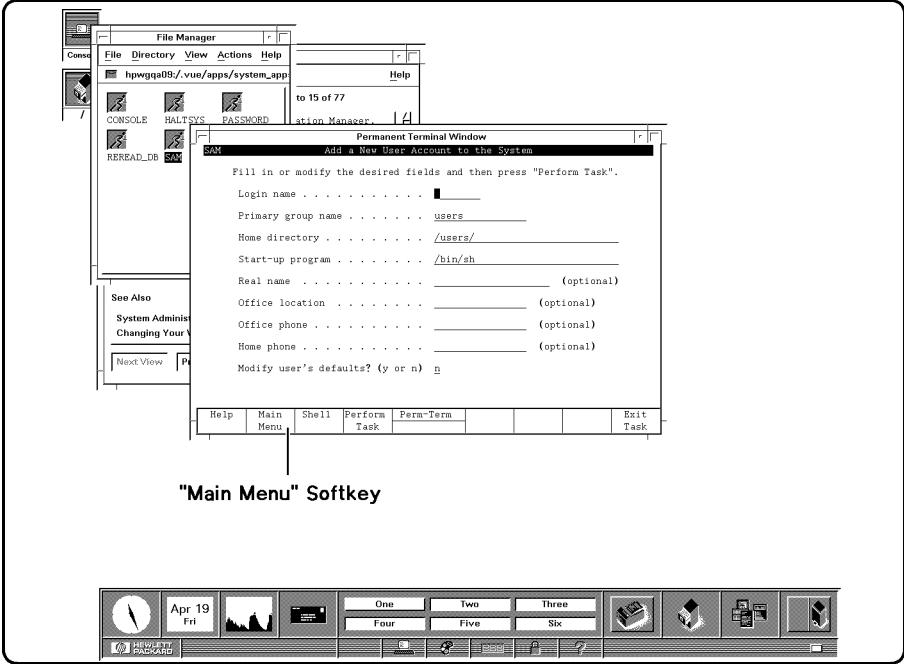

16 Click on the **Exit SAM** softkey.

To close the Permanent Terminal Window, move the mouse pointer over the window menu button in its upper left-hand corner and double-click the left mouse button.

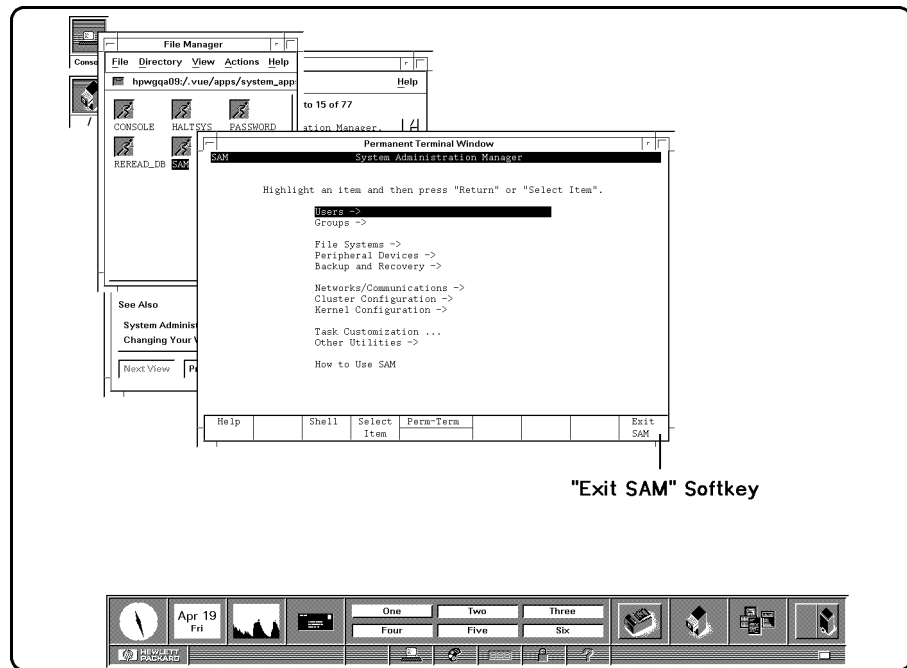

Setting a New Password

In addition to setting a password when you set up a regular user account, you will want to change your password from time to time as a matter of good security practice.

A password must meet four criteria to be valid:

- Contain at least six characters.
- At least two characters must be alphabetic.
- At least one character must be a number (0-9) or a special character (/, ?, !, or other punctuation mark).
- Differ from your previous password by at least three characters.

Your password is case-sensitive, so the password ?**Secret** is different from the password ?**secret**. Your password can also be as long as you want, but only the first eight characters are checked.

To set a password using VUE:

1. Click the applications directory button on the Workspace Manager to display the applications directory.
2. Double-click the `system_apps` folder to open that subdirectory.
3. Double-click the `sys_admin` folder.
4. Double-click the `PASSWORD` icon to start that application.
5. Type your new password after the **New password** prompt and press **Return**. What you type doesn't appear on the screen.
6. Verify your new password, as requested, by retyping it and pressing **Return**.

Use the same procedure to change an old password as to add a new password. If you already have one, you will be prompted appropriately for the old password.

Shutting Down Your Computer

Caution Do not turn off the power to your computer without first doing these shutdown procedures. If you do not shut down your computer properly, you may damage the programs and data on your disk.

When you need to shut down your computer so it can be powered off, you should follow these steps. Doing this will ensure that your file system remains intact and that you can power-up and login correctly.

- 1 You must be logged in as `root`. If you are not, logout, then login as `root`.

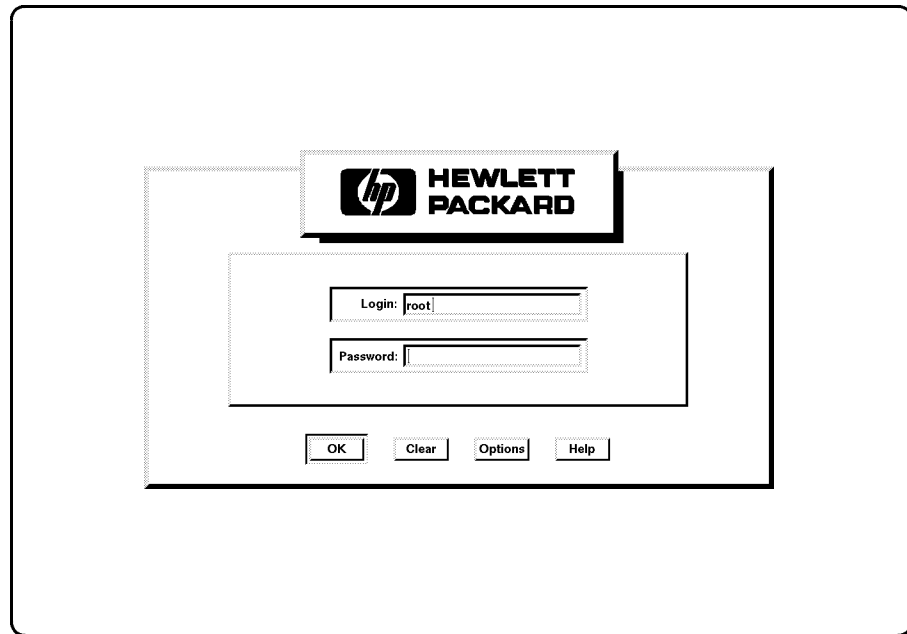

- 2 Click on the control panel's application button. That's the one with the pages on it.

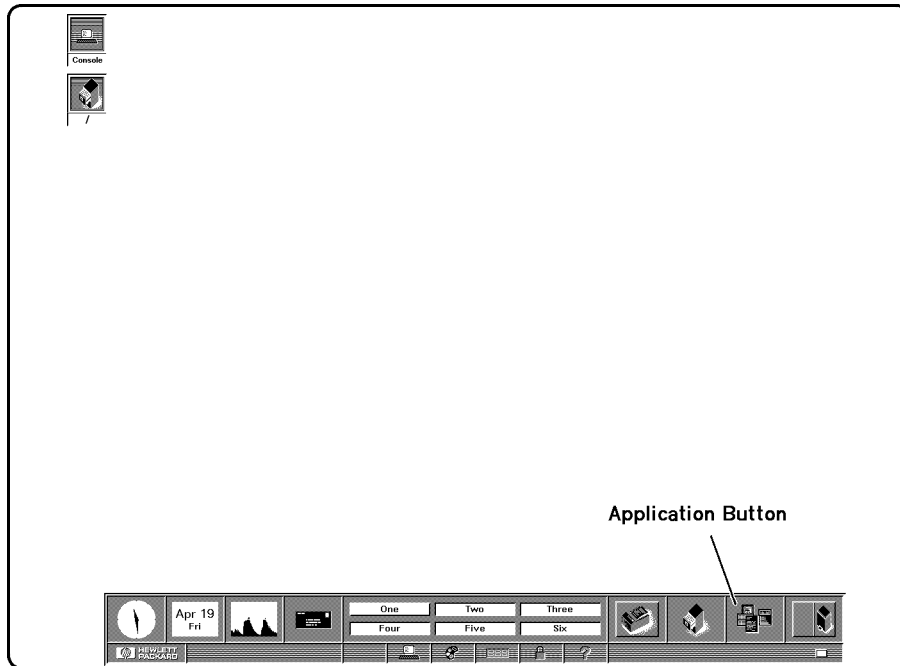

- 3 When this window appears, move your pointer onto the `system_apps` folder and double-click the left mouse button.

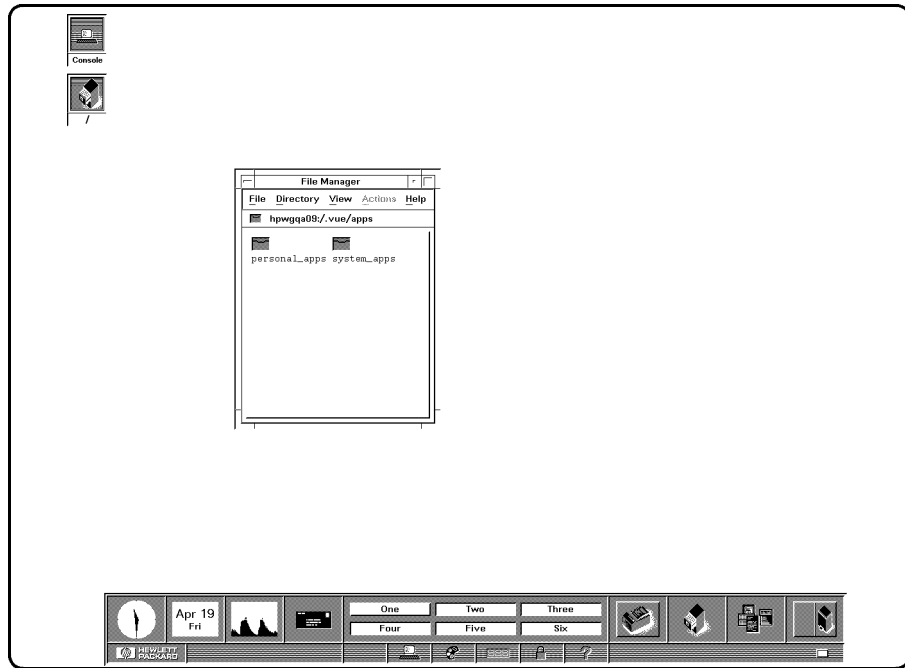

- 4 When this window appears, move your pointer onto the `sys_admin` folder, then double-click the left mouse button.

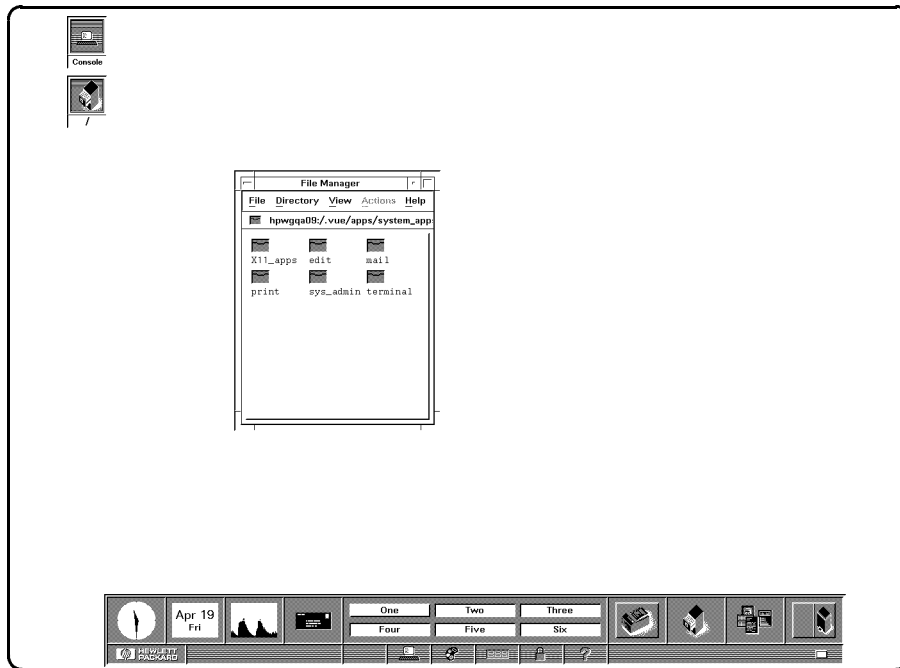

5 When this window appears, double-click on the HALTSYS icon.

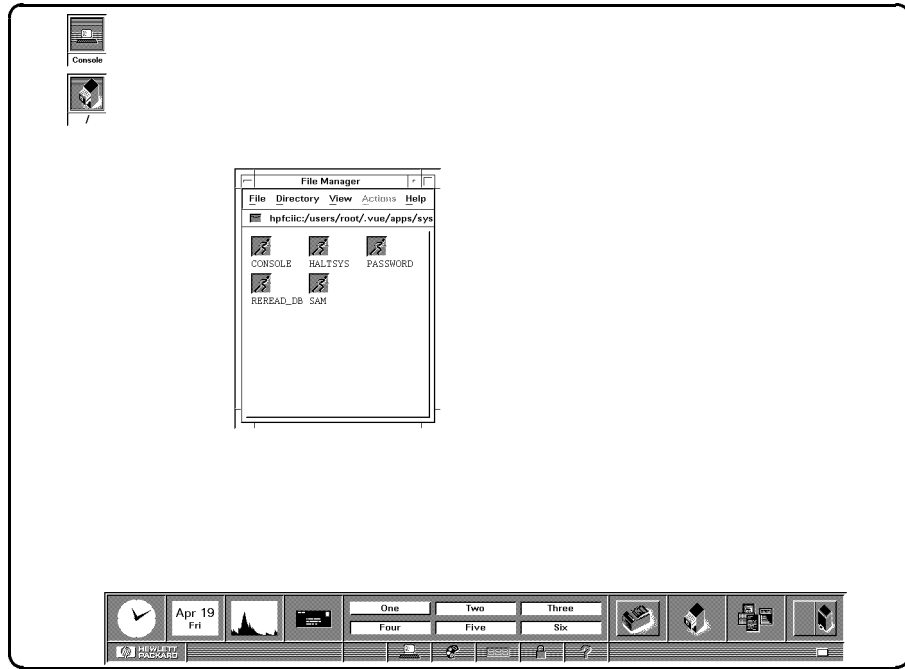

- 6 When the Halt System window appears, click on the screen button marked “OK, Halt System.” Any other users who are logged onto your computer will get a warning that the computer will soon be unavailable. In one minute, the system will begin its shutdown process.

If you do *not* want to shut down your system, click on the screen button marked “No, Cancel.”

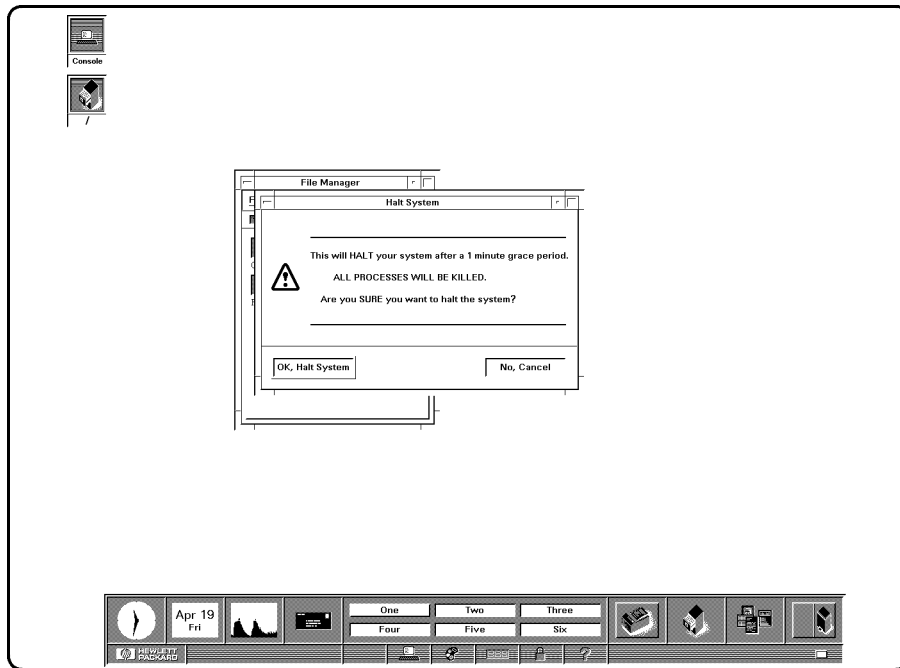

7 The shutdown process takes about one minute.

These lines appear at the lower left-hand corner of your screen:

```
Halted (in a tight loop) -- OK To Hit Reset Button
```

You may now turn off your computer.

- 8 The next time you turn on your computer, its HP VUE login screen should appear within five minutes.

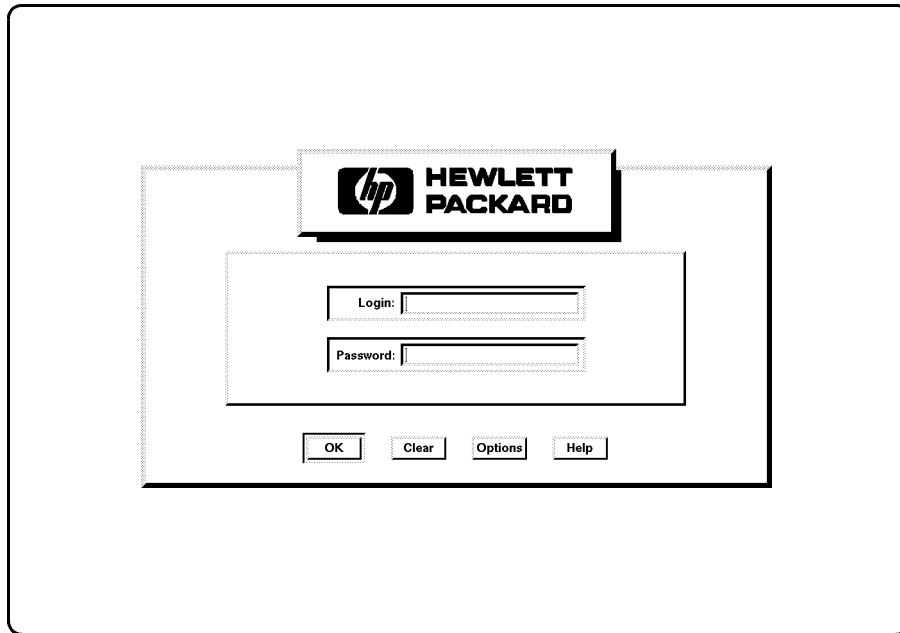

For More Information ...

To learn more about the HP-UX window environments, refer to *HP Visual User Environment User's Guide*, *The HP Visual User Environment System Administration Manual* and *Using the X Window System*.

Using Your Computer

This chapter will help you decide how to interact with your HP Apollo 9000 Model 750 computer. It describes the following:

- System software interfaces
 - The two types of HP-UX user interfaces you may use:
 - HP Visual User Environment (HP VUE)
 - HP-UX shells
 - Sample interactions in each HP-UX user interface
 - Further resources for learning more about the HP-UX user interfaces

Note If you purchased your HP Apollo 9000 Model 750 computer with pre-loaded system software, it will start up in HP VUE. If you prefer not to use HP VUE, you may disable it by following the directions in “Disabling HP VUE from Your Computer” in Appendix A of *HP Visual User Environment User’s Guide*.

- The system hardware interface
 - The boot console user interface
 - Tasks that you may accomplish by interacting directly with the hardware

About HP VUE

The HP Visual User Environment (HP VUE) is a **graphical interface** through which you can communicate with your computer. It is similar to the windowing systems that are used on many personal computers. However, since the underlying operating system is HP-UX, you will be able to do much more with this system than you could with a machine equipped with less capable system software.

This added power does not mean that your computer must be difficult to use. HP VUE allows users to accomplish the most common interactions by manipulating graphical objects with a mouse, reducing the time it takes to learn how to use HP-UX.

Working with HP VUE

The following examples are typical of tasks to be accomplished with HP VUE. The details of the display appearance will differ from that of your computer; these examples are only for the purpose of illustrating how you can interact with HP VUE and to help you to decide whether you prefer to work with the HP Visual User Environment or one of the shells.

Like other graphical user interfaces, HP VUE provides **windows** for various applications that run on your computer. In a networked environment, some of these applications may be running on other computers. The windows can accept input from the keyboard, mouse and other devices and display the applications in a variety of ways.

Many of the windows are under the control of **managers**, which are software systems that determine the nature and style of your interactions with parts of the HP-UX operating system. For more information about managers, see the *HP Visual User Environment User's Guide*.

One of the managers, called the Workspace Manager, works with the system's builtin terminal emulators to provide windows that act like the screens of text terminals. When you open one of these terminal windows, you will be able to use the command line interface, or "shell." For information on using a shell, see "About Shells" later in this chapter.

About Directories and HP VUE File Managers

Manage the information you store in your computer with the **file manager**. Your computer uses **files** to hold data. **Directories** are “folders” that hold files *and* other directory folders.

1. Move the mouse pointer over the file manager icon and press the *left mouse button* to open the file manager.

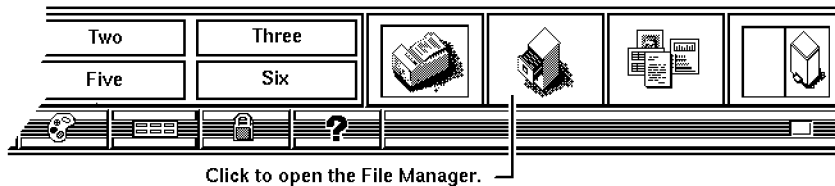
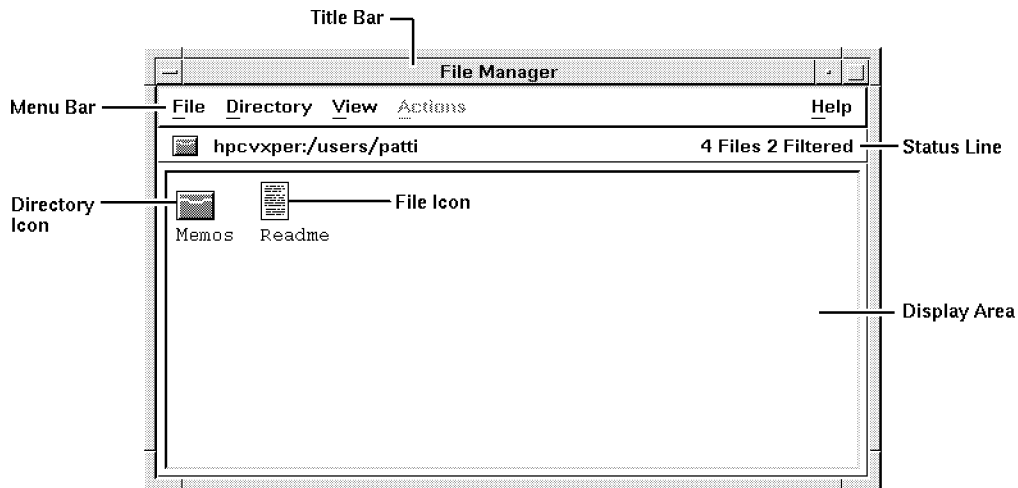

Note Your computer shows different files than those pictured. The file manager illustrated here displays the **home directory** of the user **patti**.

The following examples assume that two file managers are open on the screen.

3-4 Using Your Computer

Example 1: Moving a File

1. If your two file manager views overlap, move the overlapping view below the underlying view by moving the mouse pointer onto the title bar (marked **File Manager**) of the overlapping window, pressing and holding down the *left mouse button*, dragging the window away from the underlying window so you can see the display areas of both, and releasing the mouse button.
2. Press and hold down the *middle mouse button* on the file to be moved from one of the file managers.
3. Drag the file to the other file manager display area, ensuring that it is over an empty area.

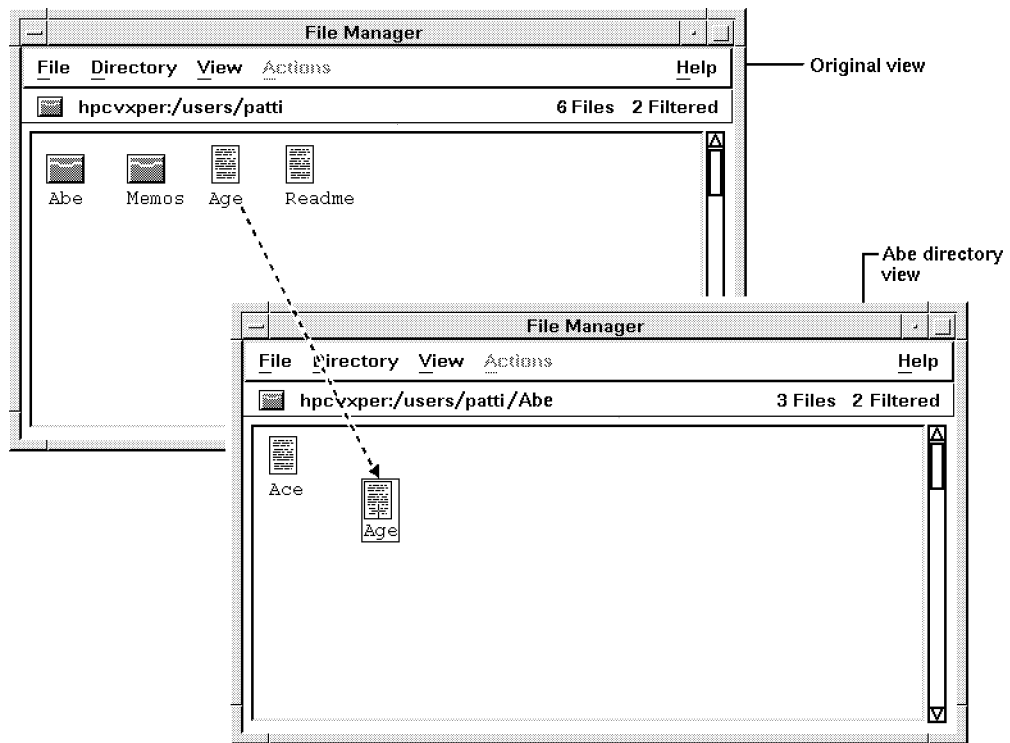

4. Drop the file (release the mouse button).

Example 2: Copying a File

1. Move the pointer over the file to be copied.
2. Press and hold down **CTRL**.
3. Press and hold down the *middle mouse button*.
4. Drag the file over an empty area in the display area of the file manager window into which it is to be copied.

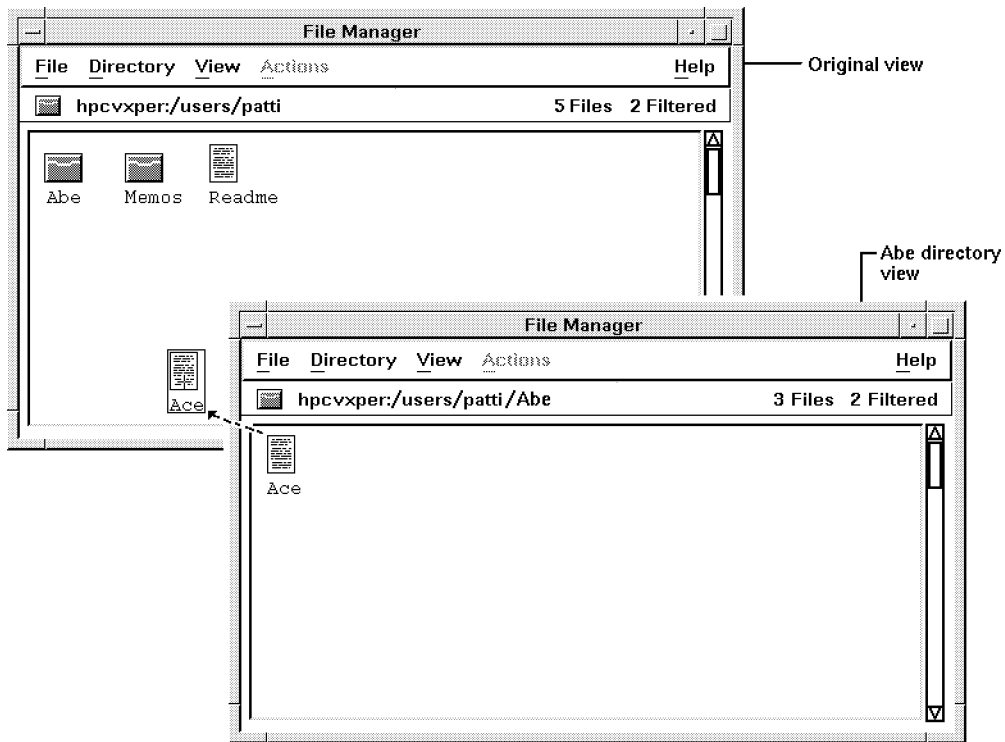

5. *While still holding down **CTRL***, drop the file (release the mouse button).
If you release **CTRL** before the mouse button, the file is moved instead of copied.
6. Release **CTRL**.

3-6 Using Your Computer

Learning More about HP VUE

To learn more about the HP Visual User Environment, read the *HP Visual User Environment User's Guide*. This book explains many of the features of the different HP VUE managers and provides examples of how they may be used.

About Shells

In systems equipped only with text terminals, HP-UX usually communicates with the user through a **shell**. A shell is a program that captures text typed on the terminal's keyboard, interprets the text into commands and data, transmits the commands to the operating system, and prints the results of the commands' execution (and any resulting messages) on the terminal's screen. A shell is sometimes also called a **command interpreter** or **command processor**.

When you interact with your computer using the entire screen as a terminal (that is, if you do *not* use OSF/Motif or another window environment), you will use the shell in much the same way you would if you were working on a text terminal.

If you set up your computer to run HP VUE or the OSF/Motif window environment upon which it is based, each terminal window that you open with `hpterm` or `xterm` runs a shell program. You may open many terminal windows, and they may communicate with your computer's processor or the processors of other computers connected to a network.

Table 3-1 lists some of the features of the shells available in HP-UX.

Table 3-1. HP-UX Shells

Shell	Features
Bourne Shell	The default shell for HP-UX. It is compatible with most of the shell programs provided with your system.
Korn Shell	An upwardly-compatible extension of the Bourne Shell, with many new features: <ul style="list-style-type: none">■ A command history buffer■ Command aliases■ Pathname completion■ Job control■ Interactive command-line editing
Key Shell	An upwardly-compatible extension of the Korn Shell. It makes use of softkeys function keys to “build” HP-UX command lines, which are translated and executed automatically. Key Shell includes these features: <ul style="list-style-type: none">■ “Keystroke” execution of 22 commands■ Softkey display of options for 70 common HP-UX commands■ User-configurable status line■ Context-sensitive help■ Support for editing keys like Delete line
C Shell	This shell has a command syntax that resembles the C programming language. For this reason, it is often favored by C programmers.

Working with a Shell

The following examples are typical of tasks to be accomplished with a shell. They work in the same way in any of the four shells.

The filenames used in the examples will differ from those that are on your computer; these examples are only for the purpose of illustrating how you can interact with an HP-UX shell and to help you to decide whether you prefer to work with the HP Visual User Environment or one of the shells.

This is the general form of the HP-UX commands used in the examples:

command_name argument(s)

The *command_name* is the name of an HP-UX command. The *argument* is the data that the command will act upon. There may be more than one *argument*. In the following examples, all of the *arguments* are file names.

About Directories

You will understand the following examples better if you know something about **directories**. In HP-UX, a file is a “container” for data. A directory is a “container,” too, but it contains files. A directory may also contain other directories.

A file’s location may be described by writing the “chain” of directories one must pass through to find the file. In HP-UX, the highest-level directory is called the **root directory**. It is designated by the “slash” symbol:

`/`

A directory called **users** that is contained in the root directory is designated in this way:

`/users`

The directory **users** is said to be a **subdirectory** of the root directory. It may in turn contain other subdirectories. Here is how a **users** subdirectory called **terry** is designated:

`/users/terry`

If `/users/terry` contains a file called `myfile`, this is how it is designated:

```
/users/terry/myfile
```

Because this describes the “path” one must follow from the root directory to locate `myfile`, `/users/terry/myfile` is a **path name**.

Example 1: Moving Files

Use the `mv` command to move files from one directory to another. For example, to move `myfile` into the `projects` directory, type:

```
$ cd                                Move to your home directory first.  
$ mv myfile projects
```

Now verify that it worked:

```
$ lsf                                List your current working directory.  
projects/                            Where did myfile go?  
$ lsf projects                       Look in the projects directory.  
myfile    new/        old/         There's myfile. It worked!
```

A single dot (`.`) for a path name represents your current working directory. Therefore, to move `myfile` from the `projects` directory back to your current working directory, type:

```
$ mv projects/myfile .                Don't forget the dot.  
$ lsf                                List your current working directory.  
myfile    projects/                 It worked; myfile is back.  
$ lsf projects                       List projects.  
new/        old/                    The file myfile isn't there anymore.
```

The general form of the `mv` command is as follows:

```
mv from_path to_path
```

where `from_path` is the file name or path name of the file you want to move, and `to_path` is the name of the path to which you are moving.

Example 2: Copying Files

To copy a file into a different directory, use the `cp` command. For example, to make a copy of `myfile` named `myfile2` in the `projects` directory, type:

```
$ cp myfile projects/myfile2
$ lsf
myfile    projects/    The file myfile still exists.
$ lsf projects
myfile2   new/        old/        The copy (myfile2) is in the projects directory.
```

To make a new version of `myfile2` named `myfile3` in your current directory, type:

```
$ cp projects/myfile2 myfile3
$ lsf
myfile    myfile3     projects/
```

The general form of the `cp` command is as follows:

```
cp from_path to_path
```

where *from_path* is the file name or path name of the file you want to copy, and *to_path* is the path name of the directory or file to which you are copying.

Changing Your Login Shell

If your system was installed for you, the installer may have chosen a shell for you. If you prefer to use another shell, you may change your shell permanently by using the `chsh` (**ch**ange **sh**ell) command:

```
chsh username full_shell_name
```

where *username* is your user name and *full_shell_name* is the full path name of the shell you want as your login shell. After you use the `chsh` command, you must log out and log in again for the change to take effect. For example, if the user `terry` changes the default login shell to the Korn Shell, the command reads:

```
$ chsh terry /bin/ksh
```

Learning More about Shells

To learn more about the HP-UX shells, read *A Beginner's Guide to HP-UX*. This book explains many of the features of the different shells and provides examples of how they may be used. For a more detailed exploration, read *A User's Guide to HP-UX Shells*, an extended tutorial on the uses of the shells. For a technical description of the shells, see *sh(1)*, *ksh(1)*, *keysh(1)*, and *csh(1)* in *HP-UX Reference*.

The Boot Console User Interface

There will be time when you will want to interact directly with the hardware of your computer *before* it boots the operating system. Your HP Apollo 9000 Model 750 provides a **boot console user interface** to allow you to perform special tasks, display information, and set certain system parameters even if the operating system is unavailable.

These are the special tasks you can perform:

- Boot your computer from any specified hardware device.
- Search for hardware devices that contain media from which your computer can be booted.
- Select an operating system for the next boot attempt.
- Reset the computer.

These are the kinds of information your system can display:

- A list of the commands you may issue from the boot console user interface
- Help in using those commands
- The real-time clock's time and date
- The operating system selected
- The settings of the **Autoboot** and **Autosearch** "flags"
- The status (on or off) of the secure boot mode
- The station address for the builtin LAN interface
- The primary boot path
- The alternate boot path
- The console path
- The keyboard path
- The versions of the I/O modules (builtin, graphics, and EISA)
- Your computer's model number
- Your computer's processor frequency
- Your computer's I/O subsystem frequency
- Your computer's SCSI jumper frequency setting
- Your computer's EISA jumper frequency setting
- The status of the LAN jumper
- The revision number of the processor
- The revision number of the system controller
- The revision number of the floating point coprocessor

These are the system parameters you can set:

3-14 Using Your Computer

- The real-time clock's time and date
- The operating system selected
- The **Autoboot** and **Autosearch** "flags"
- The status (on or off) of the secure boot mode
- The primary boot path
- The alternate boot path
- The console path
- The keyboard path

Using the Boot Console User Interface

To use the boot console user interface, follow these steps:

1. Shut down your computer. To do this, follow the steps listed in "Shutting Down Your Computer" in Chapter 2. Wait until these words appear:

```
Halted (in a tight loop) -- OK To Hit Reset Button
```

2. Turn off the computer, wait a few seconds, then turn it back on.
3. Press the **ESC** key. In a few seconds, this message appears:

```
Terminating selection process.
```

A short time later, this message appears:

```
Searching for potential boot devices.
To terminate search, press and hold the ESCAPE key.
```

```
Device Selection Device Path Device Type and Utilities
-----
```

Your computer is now searching for devices that *may* hold file systems from which it can boot HP-UX. As they are found, they appear in a list.

A list of devices might look like this:

P0	scsi.6.0	<i>disk_drive_identifier</i>
P1	scsi.5.0	<i>disk_drive_identifier</i>
P2	scsi.4.0	<i>DDS-format_tape_drive_identifier</i>
P3	scsi.3.0	<i>CD_ROM_drive_identifier</i>
P4	lan.123456-789abc	<i>cluster_server_identifier</i>

This process may take several minutes. When the search ends, this list of actions appears:

```
b) Boot from specified device
s) Search for bootable devices
a) Enter boot administration mode
x) Exit and continue boot sequence
?) Help
```

Select from menu:

This is the boot **console user interface menu**.

■ If *no* devices are listed, take these actions:

- Check for loose connections.
- Check to make sure that all the SCSI bus addresses are unique for each SCSI bus. Duplication of addresses may cause several or all of the devices on the bus to be inaccessible, and it may lead to loss of data.
- Check and verify that all peripherals are powered on.

If you have performed the address, connection, and power checks and there are still no devices listed, there is a serious problem. Contact your designated service representative for assistance.

■ If no disk devices are listed, and your system is equipped with disk drives, then your computer is failing to communicate with its disks. Recheck the SCSI connections and try again.

Of course, if your computer is a member of a **cluster** (a group of computers that share the file system of a **host** by means of a network connection), there may be no disks listed because your computer has no disks directly attached to it.

Entering the Boot Administration Mode

To change system hardware parameters, you must enter the **boot administration mode**. From within this mode, you may enter any of the commands used in the task descriptions that follow.

To enter the boot administration mode, type:

```
Select from menu: a
```

3-16 Using Your Computer

This prompt is displayed:

```
BOOT_ADMIN>
```

Exiting the Boot Administration Mode

To exit the boot administration mode, take any of the following actions:

- Type **exit** at the **BOOT_ADMIN>** prompt. This will return you to the boot console user interface menu.
- Type **reset**. This will restart the computer.
- Issue a **boot** command. See “Booting the Computer” for details.
- Turn off the computer. There is no need to shut down the computer with the special procedure described in “Shutting Down Your Computer” in Chapter 2, since the computer has not yet been booted, and the file system has not been activated.

Getting Help on the Use of the Boot Console User Interface Commands

You may issue many different commands in the boot administration mode. For a complete listing of these commands, type:

```
BOOT_ADMIN> h
```

or

```
BOOT_ADMIN> help
```

or

```
BOOT_ADMIN> ?
```

A summary of all the commands appears on your screen.

To get help for a particular command, type:

```
BOOT_ADMIN> help command_name
```

where *command_name* is the name of one of the listed commands. The displayed help information usually includes a description of the command, its options, and the format for parameters.

Booting the Computer

Usually, you will start your computer by turning it on and waiting for HP-UX to boot automatically. However, you may not wish for the usual sequence to occur.

For example, you may wish to start your computer from an operating system that is stored on a device that is different from your usual boot device. If your normal operating system kernel (`/hp-ux`) or the disk on which it resides becomes damaged or unusable, you may wish to boot from a different disk or perhaps another type of device, such as a DDS-format tape drive or a magneto-optical disk.

Here are some situations and examples:

- If you know which device you want to boot from, and you know that it contains a bootable operating system, type:

```
BOOT_ADMIN> boot device
```

where *device* is one of the following:

- The **hardware path** to the device, specified in Mnemonic Style Notation. (See Table 3-3 in the section “Displaying and Setting Paths” later in this chapter for further information.)
- The *Pn* designation of the device, as listed in the device search (see “Using the Boot Console User Interface” or “Searching for Bootable Media”).

For example, if you wish to boot an operating system that is stored on a DDS-format tape in a drive that is located at `scsi.4.0` and is designated by the search as device `P2`, type:

```
BOOT_ADMIN> boot scsi.4.0
```

or

```
BOOT_ADMIN> boot P2
```

The operating system on the specified device will be used to start your computer.

- If you wish to interact with the **Initial System Loader (ISL)** before booting your computer, type:

3-18 Using Your Computer

```
BOOT_ADMIN> boot device isl
```

This will cause the ISL to be loaded from the specified device. After a short time, this prompt will appear on your screen:

```
ISL>
```

ISL is the program that actually controls the loading of the operating system. By interacting with ISL, you can choose to load an alternate version of the HP-UX operating system.

For example, if the usual kernel (`/hp-ux`) on your root disk (`scsi.6.0`) has become corrupted, and you wish to boot your computer from the backup kernel (`/SYSBCKUP`), type:

```
ISL> hpux boot disk(scsi.6;0)/SYSBCKUP
```

- If you do *not* know the locations of the bootable operating systems on the various media in your file system, you can find out with the `search` command (see “Searching for Bootable Media”).

Note

You may also boot the computer from the main menu of the Boot Console User Interface by using a command in this form:

```
Select from menu: b device
```

where *device_path* is a designator for the path to the device that contains a bootable file system.

Searching for Bootable Media

The initial search conducted by the boot console user interface locates devices that *might* contain bootable media. This search might find a DDS-format tape drive which actually does not contain a bootable tape. To check to see which devices actually contain bootable media, type:

```
BOOT_ADMIN> search
```

This will cause your computer to search *exhaustively* for bootable media. It will search all types of I/O devices in this order:

1. builtin SCSI
2. builtin LAN

3. EISA cards

The search may turn up more devices than there are lines on your display. If you are using a text terminal, you may control the progress of the search from your terminal's keyboard:

- To hold the display temporarily, press **Control-S**.
- To continue the display, press **Control-Q**.
- To halt the search, press **Escape**.

These flow-control commands do not work with a bitmapped display, but such a display can show more than forty lines of text, so you are unlikely to need them.

Note If the search discovers ten devices, the label in the **Device Selection** column for the tenth entry will be labeled **P9**. Any subsequent entries will be labeled **P***.

P* cannot be used as a device designator for boot administration commands because it is ambiguous. To refer to a device labeled **P*** in a search, specify it by means of the entry in the **Device Path** column.

To search to see which devices of *just one type* actually contain bootable media, type:

```
BOOT_ADMIN> search device_type
```

where *device_type* is one of the following:

<code>scsi</code>	The builtin SCSI bus
<code>lan</code>	All connections to the builtin LAN
<code>eisa</code>	The EISA bus

Note You may also search for bootable media from the main menu of the Boot Console User Interface by using a command in this form:

```
Select from menu: s
```

You may also use this form:

3-20 Using Your Computer

Select from menu: `s device_type`

where *device_type* is the type of device (`scsi`, `lan`, or `eisa`) for which you wish to search.

Redisplaying the Results of a Search

The list of bootable devices is stored until you conduct another search or you reboot your system. To see the list of devices again, type:

```
BOOT_ADMIN> show
```

It is much faster to redisplay the list with `show` than it is to conduct the search again.

Displaying and Setting Paths

A **path** is the hardware address of a device that is attached to the I/O system of your computer. The `path` command can set any of the following paths:

Table 3-2. System Paths

Path Name	Device
<code>primary</code> or <code>pri</code>	Your computer's default boot device (usually the root disk)
<code>alternate</code> or <code>alt</code>	Your computer's alternate boot device (usually a DDS-format tape device)
<code>console</code> or <code>con</code>	Your computer's primary display device
<code>keyboard</code> or <code>key</code>	Your computer's primary ASCII input device

To display the current settings for the system paths, type:

```
BOOT_ADMIN> path
```

The paths will be displayed in **Mnemonic Style Notation**. This notation displays paths in these formats:

Table 3-3. Mnemonic Style Notation

I/O Type	Specification Format
EISA SCSI	<code>eisa.slot.scsi_address.logical_unit_number</code>
Other EISA/ISA	<code>eisa.slot.other_info</code> ¹
Builtin SCSI	<code>scsi.scsi_address.logical_unit_number</code>
Builtin LAN	<code>lan.server_address.init_timeout.io_timeout</code>
Builtin HIL	<code>hil</code>
RS-232 Port A	<code>rs232_a.baud_rate.word_length.parity_option</code>
RS-232 Port B	<code>rs232_b.baud_rate.word_length.parity_option</code>
Graphics slot	<code>graphics_1</code> ² and <code>graphics_2</code> ³
Builtin parallel port	<code>parallel</code>

¹ See your SCSI card documentation for information about board-level information, function blocks, choice blocks, attributes, and other EISA/ISA card information.

² The `graphics_1` path maps to graphics slot 0 (the center slot in the top section of the system unit, as viewed from the rear). This path is *not* supported for HP-UX 8.05.

³ The `graphics_2` path maps to graphics slot 1 (the leftmost slot in the top section of the system unit, as viewed from the rear). This is the *only* graphics path supported for HP-UX 8.05.

To display the current setting for a particular system path, type:

```
BOOT_ADMIN> path path_type
```

where *path_type* is one of the path types listed in Table 3-2. For example, to get the path to the primary boot device, type:

```
BOOT_ADMIN> path primary
```

To set a system path to a new value, type:

```
BOOT_ADMIN> path path_type path
```

where *path_type* is one of the path types listed in Table 3-2 and *path* is the specification of the path in Mnemonic Style Notation (as described in

3-22 Using Your Computer

Table 3-3. For example, to set the console path to RS-232 Port A with a baud rate of 4800, a word length of 7, and even parity, type:

```
BOOT_ADMIN> path console rs232_a.4800.7.even
```

For help in using the `path` command, type:

```
BOOT_ADMIN> help path
```

or

```
BOOT_ADMIN> help path_type
```

where *path_type* is one of the path types listed in Table 3-2. The help screens offer complete descriptions of all path options.

Selecting an Operating System

Your computer currently uses the HP-UX operating system, so it is set up to load HP-UX. At some time in the future, you may decide to use the OSF operating system.

To check which operating system your computer is currently configured to load, type:

```
BOOT_ADMIN> os
```

Your computer will respond with one of the following:

HPUX or HP-UX Hewlett-Packard Unix

OSF the Open Software Foundation's operating system

To set up your computer to load an OSF system, type:

```
BOOT_ADMIN> os osf
```

To set up your computer to load HP-UX again, type:

```
BOOT_ADMIN> os hpux
```

or

```
BOOT_ADMIN> os hp-ux
```

For this change in operating systems to take effect, you must reset your computer (see "Resetting the Computer"), or turn it off and back on again.

Resetting the Computer

The act of resetting your computer causes it to restart completely. It's similar to turning the computer off and then back on again. To reset your computer, type:

```
BOOT_ADMIN> reset
```

Displaying and Setting the Real-time Clock

It is usually a good idea to set the real-time clock in your computer with the HP-UX `date` command, since that command contains special safeguards that can help you to avoid disruption of time-related processes (like those controlled by the `cron` command). But you may set the clock from within the boot administration mode if you wish.

To display the current setting of the real-time clock, type:

```
BOOT_ADMIN> date
```

Your computer will report the information in this form:

```
Mon Jul 1 14:55:05 GMT (19:91:07:01:14:44:05)
```

To set the real-time clock, type:

```
BOOT_ADMIN> date century:year:month:day:hour:minute:second
```

For example, to set the clock to July 1, 1991, 2:44:05 PM GMT, type:

```
BOOT_ADMIN> date 19:91:7:1:14:44:5
```

Note

The boot administration mode's `date` command only "understands" Greenwich Mean Time (GMT). You must compute GMT relative to your own time zone to get the correct value for *hours* (and in some time zones, *minutes* as well).

Displaying and Setting the Autoboot and Autosearch Flags

`Autoboot` and `Autosearch` are **flags** (variables) stored in your computer's **non-volatile memory**. (Non-volatile memory retains its contents even after power is turned off.) If you reset these flags to new values, the change will take effect the next time you reboot the computer.

To examine the state of the `Autoboot` and `Autosearch` flags, type:

```
BOOT_ADMIN> auto
```

If `Autoboot` is set to `on`, when your computer is turned on, it will automatically attempt to boot the operating system. If it is set to `off`, your computer will enter the boot console user interface instead.

To change the state of the `Autoboot` flag, type:

```
BOOT_ADMIN> autoboot state
```

where *state* is `on` or `off`.

If `Autosearch` is set to `on`, when your computer enters the boot console user interface, a search for all potential bootable devices takes place.

To change the state of the `Autosearch` flag, type:

```
BOOT_ADMIN> autosearch state
```

where *state* is `on` or `off`.

Note

Set both `Autoboot` and `Autosearch` to `on` if you wish to have your system boot automatically from the first device it finds in its search. If you wish to have your system come up in the Boot Console User Interface instead, set both `Autoboot` and `Autosearch` to `off`.

It is not recommended to set `Autoboot` and `Autosearch` to any other combination of values.

Displaying and Setting the Secure Boot Mode

There may be circumstances in which you would not wish to allow anyone to attempt to boot your computer from a device *other* than the device you have specified, nor to control the system from any console other than the one you have designated. This can be an important consideration in secure installations.

If you set up your system in such a way that it is physically impossible for unauthorized persons to *disconnect* it from its designated boot device(s), you can guarantee that the boot console user interface cannot be used to boot the system from an unauthorized device or to change the console path. If the secure boot mode is set to **on**, the boot console interface cannot be activated; thus you are assured that your system's security cannot be compromised through interaction with that interface.

To check the status of the secure boot mode, type:

```
BOOT_ADMIN> secure
```

The value **on** or **off** will be displayed.

To set the secure boot mode to **on**, type:

```
BOOT_ADMIN> secure on
```

Resetting the Secure Boot Mode

Once the secure boot mode is set to **on**, the only way to reset it to **off** is to disconnect the boot device(s). Follow these steps:

1. Shut down your computer, turn it off and disconnect the power cable.
2. Disconnect your computer from its boot device(s). This will probably involve special procedures (specific to your site) for gaining access to the boot device(s).
3. Turn on your computer. The boot console interface will reappear.
4. Enter the boot administration mode.
5. Type:

```
BOOT_ADMIN> secure off
```

3-26 Using Your Computer

6. Turn off your computer.
7. Reconnect the boot device(s).
8. Turn your system back on.

Displaying the LAN Station Address

The **LAN station address** of your computer is the label that uniquely identifies the LAN connection for your computer at the **link level** (the hardware level). It is sometimes necessary for you to supply this address to others. For example, if your computer is to become a member of a cluster, the cluster administrator will need to know your LAN station address in order to add your computer to the cluster.

To display your computer's LAN station address, type:

```
BOOT_ADMIN> lan_addr
```

The LAN station address will be displayed as a twelve-digit number in hexadecimal notation, like this:

```
LAN Station Address: 123456-789abc
```

— |

| —

— |

| —

Protecting Your File System

The programs and data on your disks are of great value, and you should have procedures in place to make periodic copies of them on another medium, such as DDS tape. Such a copy of your file system is called a **backup**.

You may use a backup for several purposes:

- to restore individual files you may have deleted accidentally
- to restore *all* files in the event of a disk failure

A backup need not contain all the files on your system, and files may be copied to or from it one at a time. You make a backup with the **fbbackup** utility, and it is restored with the **frecover** utility.

You can make a different type of backup (called a **disk image**) using the **dd** command or a utility provided on the Support Medium. See “Creating a Disk Image” and “Using the Backup System Disks Main Menu Option” in Chapter 6 for more information.

Note You should back up your disks on a regular basis. See *System Administration Tasks* for a complete discussion of the various backup strategies and the correct use of **fbbackup**.

Protecting Your System from the Effects of a System Crash

The most important use of a backup is to recover from a **system crash**. In the most serious type of system crash, it is impossible to reboot your system from the root disk because the data on the disk has been corrupted, or the disk itself may have been damaged. In this situation, you must boot your computer from an alternate device, such as a DDS tape drive.

You cannot boot your system from a backup. You can start your system only from a bootable image on a disk or on a tape. A **recovery system** contains such a bootable image, along with a small subset of your file system, just enough to get your computer started after a disk failure. Unlike a backup, a recovery system can be used to start your computer. Once you get the computer operating again, you can restore all of your files from a backup.

For instructions on creating a recovery system, see “Creating a Recovery System”, the next section in this chapter. For instructions on using a recovery system, see “Using the Recovery System” in Chapter 6.

Creating a Recovery System

You need some knowledge of **device files** to create a recovery system. The DDS tape drive and the disks inside your system use device files to receive and transmit data. The DDS tape drive uses the device file called `/dev/update.src`

The procedure described here assumes that you are using a DDS tape drive to create a recovery system. You may use other devices for the recovery system, such as a magneto-optical disk or a spare hard disk. You may not use a floppy disk, though, because it does not have enough storage capacity to hold the recovery fileset.

To create a recovery system:

1. Log in as superuser (`root`). See *A Beginner's Guide to HP-UX* for information on how to log in from the shell prompt.
2. Prepare a DDS tape cassette for use as a recovery system. Make sure that the cassette is *not* write-protected. To do this, check the rear of the cassette. You will see a sliding tab in one corner. This tab is used to open

4-2 Protecting Your File System

and close the “recognition hole” in the cassette. If the hole is open, the cassette is write-protected; if it is closed, data may be written on the tape. If necessary, slide the tab to *close* the recognition hole.

3. Create the recovery system by using the `mkr`s command. `mkr`s has the form:

```
/etc/mkr s [-v] [-q] [-s] [-f rdev] [-r rootdev] [-m series]
```

For example, if you are creating a recovery system on a DDS-format tape drive associated with the device file `/dev/rmt/0m`, and the root device is associated with the device file `/dev/dsk/6s0`, type:

```
/etc/mkr s -v -q -s -f /dev/rmt/0m -r /dev/dsk/6s0
```

This will create a recovery system in `/usr/tmp` (on disk) and copy it over to the DDS-format tape drive after it is “built.” The recovery system will contain a small but useful subset of the system files. Your system will print a summary description of its actions on the screen as the recovery system is being created.

Note To use the `-q` option, you must have at least 10 megabytes of space available in `/usr/tmp`.

See the following section, “Using the `mkr`s Script”, for details on options and defaults.

For the devices and options in the example command line, the process of building a recovery system begins with this message:

```
Building a series 700 DAT recovery system on /dev/rmt/0m
for the disk corresponding to /dev/dsk/6s0
```

```
Are you sure you want to continue (y/n)?
```

4. To continue, press `(Y)` `(Return)`. To stop the process, press `(N)` `(Return)`.

If you continue, this message appears:

```
Place media in drive, once busy light remains off hit <Return>.
```

5. Put the DDS tape cassette into the system’s tape drive.
6. When the tape has finished loading, press `(Return)`.

A series of messages follows, reporting the progress of the creation of the recovery system. The process takes less than ten minutes. When the recovery system is completed, the DDS-format tape drive will eject the cassette.

If `mkrs` doesn't exist on your system (you'll receive a message `file not found`), use the information on adding filesets in Chapter 5, "Updating HP-UX", in *Installing and Updating HP-UX*, to add the `aconfig` fileset to your system.

7. Boot the recovery system to verify that it works. For this step, you will need to shut down the system (see "Shutting Down Your Computer" in Chapter 2). Once the system is turned off, follow the procedure in "Booting the Recovery System" in Chapter 6 to boot the recovery system.

You probably will want to test-boot the recovery system during off hours if other people use your system.

8. Put the recovery system in a safe place and lock it up.

When you boot using the recovery system, you come up as the root user. This is potentially a serious security problem. It is up to you, the system administrator, to keep this recovery system safe, so you can use it if you need to, and unauthorized people can't get at it.

9. If you loaded the `aconfig` fileset just to create a recovery system, you may wish to recover the disk space used by `aconfig`.

To remove the fileset, follow the instructions in "Removing System Files" in *System Administration Tasks*.

4-4 Protecting Your File System

Using the `mkr`s Script

The `mkr`s command has the form:

```
mkrs [-v] [-q] [-s] [-f rcdev] [-r rootdev] [-m series]
```

where:

rcdev is the name of the device file for the cartridge tape drive on which you will create your recovery system. The `mkr`s command will, by default, look for the following device files:

<code>/dev/update.src</code>	if it exists as a character device file, else
<code>/dev/rct/c0</code>	if it exists as a character device file, else
<code>/dev/rct</code>	if it exists as a character device file, else the device file must be specified.

If none of the above defaults exists on your system, you must either create one of them or specify the recovery device file using the `-f` option. The recovery device file can be either a block or a character device file. An error message will result if the user does not use one of the defaults and does not specify a recovery device file name.

The `-v` option specifies you want to see a running history of the construction of the recovery system.

The `-q` option specifies that the recovery system's image be created in the `/tmp` directory before being copied to the recovery media (the `-q` option is the default for a DDS tape recovery system). This option saves time due to seeking on DDS tape media.

The `-s` option specifies that a smaller set of system files be placed on the recovery media; this applies when making a DDS tape recovery system for a small memory system. The `-s` option is *required* when building a recovery system for a Series 700 computer on DDS-format media.

rootdev is the name of the device file for the root device. The **mkrs** command will, by default, look for the following root device files:

- `/dev/dsk/0s0` if it exists as a block device file, else
- `/dev/root` if it exists as a block device file, else
- `/dev/hd` if it exists as a block device file, else the device file must be specified.

If none of the above defaults exists on your system, you must either create one of them or specify the root device file using the **-r** option. The root device file must be a block device file. The character device file need not exist. An error message will result if a default root device file does not exist and you do not specify a root device file name.

series Normally not needed. If **mkrs** cannot determine the type of system you have it will send you an error message. If this happens re-execute **mkrs** using the **-m** option with the value 700.

For example, if your root file system had the device file `/dev/dsk/0s0`, and you were creating your recovery system on a cartridge tape drive which had the device file `/dev/update.src`, you would type the following command:

```
mkrs
```

The **mkrs** process takes about ten minutes.

“Using the Recovery System” in Chapter 6 explains how to use the recovery tape to restore your system.

For more information about `/etc/mkrs`, see the *mkrs(1M)* manual page in *HP-UX Reference*.

4-6 Protecting Your File System

Backing Up Your Programs and Data

Your data is precious. Back it up often. Consult *System Administration Tasks* for backup strategies.

There are two types of backups:

- Backup tape A tape that contains copies of some or all the files on your system.
- Disk image A bit-for-bit copy of your disk(s). Such an image is usually made on some other medium (a DDS-format tape, for example), but it may also be made on another disk.

Backup tapes and disk images differ from one another in one important way. A backup tape need not contain all the files on your system, and files may be copied to or from it one at a time. This is not possible with a disk image. A backup tape is a more flexible tool for maintaining the security of your data.

Making an Archive Backup

An **archive backup** contains *all* the files on your system. You should make an archive copy of your file system as soon as your system is installed. If you ordered your system with preinstalled software, you may not have access to the installation tapes, so the *only* way you can be sure that you can restore all your files is to make an archive of them immediately.

To make an archive copy of your file system:

1. Log in as **root**.
2. Open a terminal window.
3. Load a write-enabled medium (for example, a DDS-format tape) into the backup device.
4. Type:

```
$ fbackup -f backup_device -0 -v -i /
```

where *backup_device* is the device file associated with the backup device. For example, to back up all your files to a DDS-format tape in a tape drive located at `/dev/rmt/0m`, type:

```
$ fbackup -f /dev/rmt/0m -0 -v -i /
```

5. If `fbackup` requires more than one medium to complete the backup, it will prompt you to insert one in the backup device.

You can use `fbackup` in many different ways to provide complete and efficient backup of your file system. See *System Administration Tasks* for more information.

Creating a Disk Image

You need some knowledge of **device files** to create a disk image. The DDS tape drive and the disks inside your system use device files to receive and transmit data. The DDS tape drive uses the device file called `/dev/rmt/0mn`. The root (`/`) disk uses `/dev/rdisk/6s0`, and the user (`/usr`) disk uses `/dev/rdisk/5s0`.

To create a disk image:

1. Shut down your system, and put it into single-user mode. To do this, log in as `root` and type:

```
$ shutdown
```

After a one-minute pause, this will bring all processes on your computer to a halt and cause it to reboot into a mode in which `root` is the only user.

Note If other users are logged into your computer, they will receive a message to the effect that their sessions will end in 60 seconds. They will have to stop whatever they are doing and save any open files.

2. Log in as superuser (`root`). See *A Beginner's Guide to HP-UX* for information on how to log in from the shell prompt.
3. Put a DDS tape cassette into the system's tape drive. Make sure that the cassette is *not* write-protected. To do this, check the rear of the cassette. You will see a sliding tab in one corner. This tab is used to open and close the "recognition hole" in the cassette. If the hole is open, the cassette is write-protected; if it is closed, data may be written on the tape. If necessary, slide the tab to *close* the recognition hole.
4. The command to copy a disk image onto tape looks like this:

4-8 Protecting Your File System

```
$ dd if=disk_filename of=DDS_tape_device_filename
```

If you want to copy the disk located at `/dev/rdisk/6s0`, type:

```
$ dd if=/dev/rdisk/6s0 of=/dev/rmt/0m bs=10k
```

This will cause the image of the disk to be copied to the DDS tape cassette. The length of time it takes to copy a disk image varies with the characteristics of different types of disks, but the copy could take up to an hour to complete.

5. Copy any other disks in a similar fashion. Use a *separate tape* for *each* disk image. If you copy two or more images onto the same tape, only the first one can be restored.

— |

| —

— |

| —

Expanding Your Computer and Replacing Its Parts

Your HP Apollo 9000 Model 750 computer can be expanded and modified in many ways:

- additional memory
- additional mass storage devices
- different graphic display systems

This chapter contains descriptions and illustrations of how to add these options to the system unit.

It also contains the procedures for removing and replacing your computer's internal components, should that ever be necessary. Each procedure references one or more illustrations for the task at hand. You will find a list of the replaceable parts under the heading "Replaceable Parts List".

This chapter does *not* include procedures to replace components in any external graphics unit that may be in your system, nor are there any procedures for the monitor or any external peripherals. See the documents that accompanied these units for any such instructions. For general instructions on adding peripherals to your HP Apollo 9000 Model 750, consult *Installing Peripherals*.

Procedure Terminology

Pay special attention to the first word in each procedure's title. This keyword informs you of the type of operation you are about to undertake:

Terms	Definition
Removing	Permanent removal of a component. Example: removing a mass storage device.
Replacing	Removing a component and installing another component of the same type. Example: replacing a bad component to resolve a hardware problem.
Changing	Changing the functionality of the component. Example: changing 802.3 LAN types between thin or thick cables.
Adding	Installing a component where no previous component was installed. Example: adding an optional EISA card or increasing memory capacity.

Electrostatic Discharge (ESD) Precautions

Electrostatic discharge (ESD) can result from the buildup of static electricity on or around the components you handle. You can even carry a charge on your own body, and the discharge of this energy through a component or your computer can cause damage to the system.

Caution

Observe the following precautions at all times during these removal and replacement tasks to prevent damage to the system unit components from ESD:

- Wear a grounded static strap on your wrist to ensure that any accumulated electrostatic charge will be discharged from your body to ground.
 - Keep all uninsulated printed circuit cards in their protective antistatic bags.
 - Handle all printed circuit cards by their edges, once you have removed them from their protective antistatic bags.
-

Replaceable Parts List

Table 5-1. Major Components

Part Name	Part Number
System card	A1095-69510
SIMM card (16 Megabyte)	A1470-69521
Lithium battery	1420-0314

Table 5-2. Optional Components

Part Name	Part Number
660 megabyte disk assembly	A1095-69001
1.3 gigabyte disk assembly	A1095-69002
Microfloppy disk drive	A1094-69007
CD ROM drive	A1999-69001
SCSI terminator	1252-3932
Graphic interface card	98705-66582
24-bit color graphic display card	A1659-66001
Monochrome graphic display card	A1924-66001

Getting Ready

Perform the following steps to safely power down your computer:

1. Log in as `root` and give the superuser password for your system.
2. Shut down your system as described in “Shutting Down Your Computer” in Chapter 2.
3. Wait for these words to appear at the bottom of the screen:

```
Halted (in a tight loop) -- OK To Hit Reset Button
```

4. Turn off the power to all of the computer’s components and *remove the power cord* before replacing components or adding options to the system unit cabinet.

Replacing the System Card

Perform the following steps in the order given to replace the system card:

1. Shut down the system as described in “Getting Ready” earlier in this chapter.
2. Power down the computer and all its peripherals, and disconnect the power cord from the system unit.
3. Disconnect all the cables connected to the system card.
4. Remove the system card from the back of the system:
 - a. Remove the five screws that hold the system bulkhead in place. See Figure 5-1 (an illustration of the warning label on the system bulkhead) for the locations of the screws.

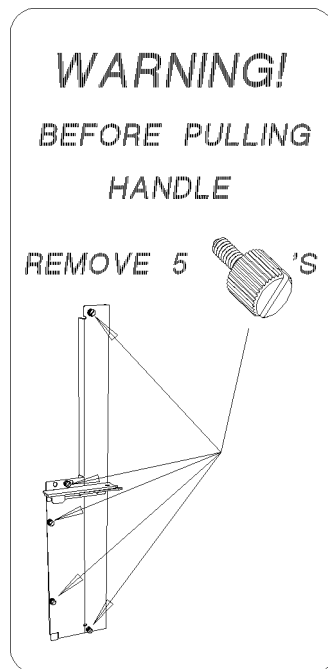

Figure 5-1.

- b. Pull out the lever near the center of the system bulkhead. This will pull the card free of the internal connector. (See Figure 5-2.)

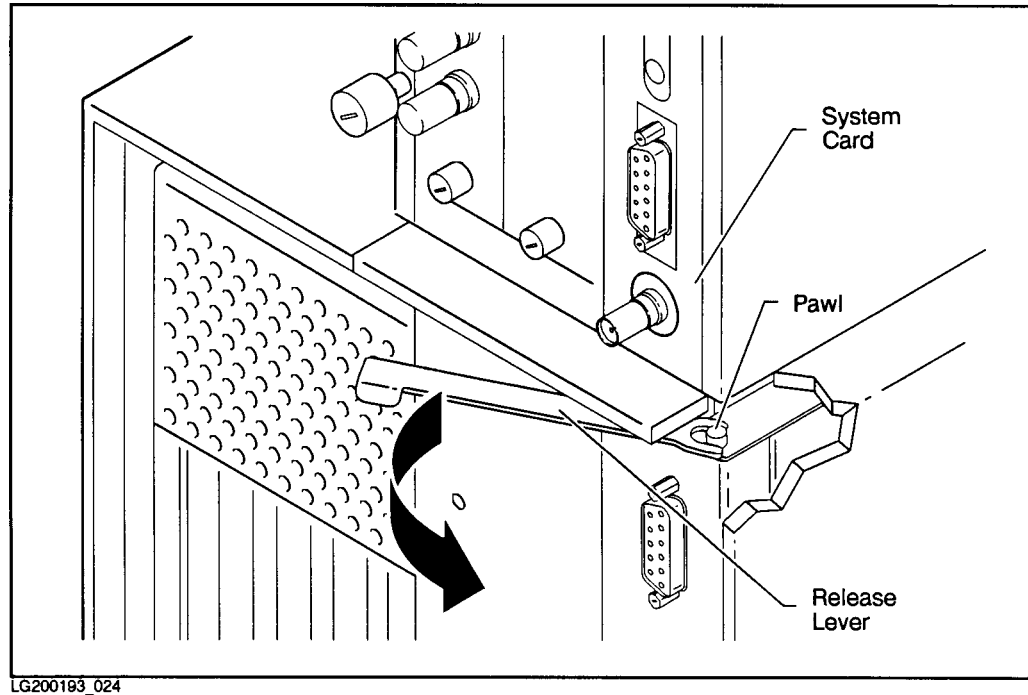
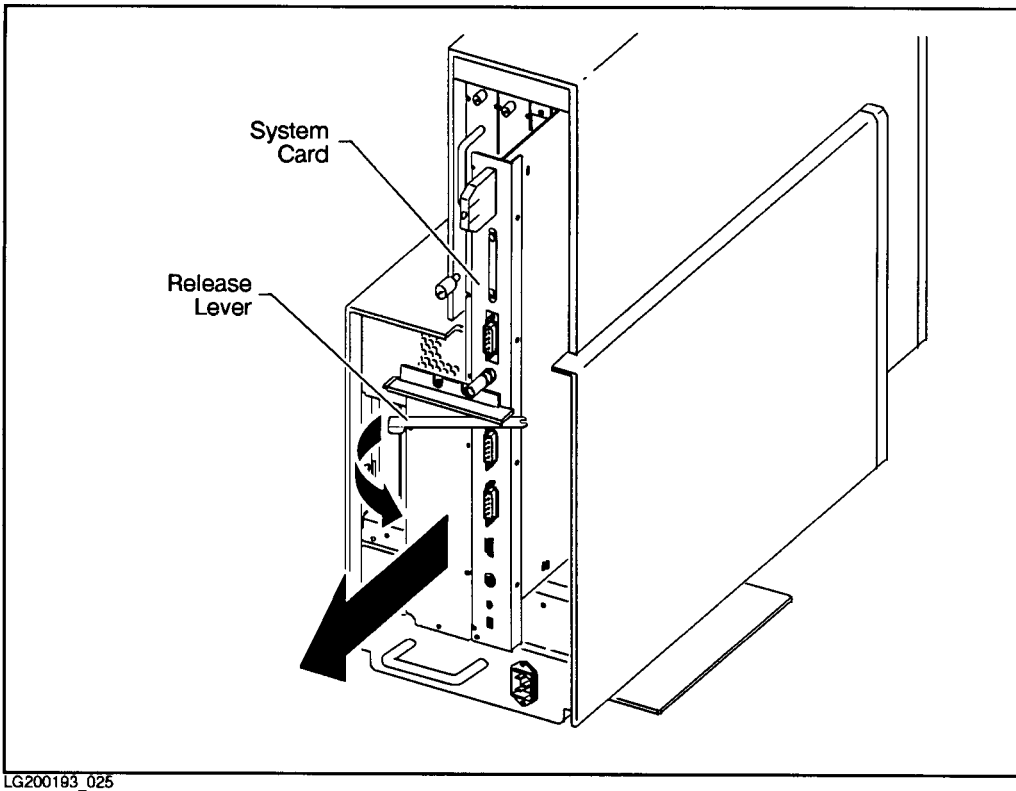

Figure 5-2. Releasing the System Card

c. Pull the system card from the back of the system unit. (See Figure 5-3.)



LG200193_025

Figure 5-3. Removing the System Card

**5-8 Expanding Your Computer
and Replacing Its Parts**

5. Remove all of the SIMM cards from the original system card and re-install them on the replacement system card. Follow the instructions in “Replacing or Adding SIMM Cards”.
6. Remove the EEPROM in socket U87 on the original system card and install it on the replacement system card. This EEPROM contains boot path and LAN identification information that must remain with the computer.
7. Configure the LAN type jumper settings on another system card with those on the original system card. Follow the instructions in “Changing 802.3 LAN Types”.
8. Install the replacement system card into the back of the system unit cabinet.
 - a. Slide the system card into the back of the system unit.
 - b. Push in the lever near the center of the system bulkhead. This will press the card into the internal connector.
 - c. Replace the five screws that hold the system bulkhead in place. See Figure 5-1 (an illustration of the warning label on the system bulkhead) for the locations of the screws.

Replacing or Adding SIMM Cards

The system card must be removed to gain access to the SIMM cards.

Perform the following steps in the order given to update, replace, or add SIMM cards plugged into the system card:

1. Shut down the system as described in “Getting Ready” earlier in this chapter.
2. Power down the computer and all its peripherals, and disconnect the power cord from the system unit.
3. Remove the system card from the back of the system unit cabinet by following the procedure described in Step 4 of “Replacing the System Card”.
4. The next step depends on whether you are replacing a SIMM card or adding additional SIMM card pairs:

- a. To replace a SIMM card:

Remove the *suspect* SIMM card on the system card and replace it with another SIMM card the same size as shown in Figure 5-4.

- b. To add additional SIMM card pairs:

SIMM cards must be added in pairs. If you add a SIMM card to slot J102, you must also add a card to slot J103. The same is true for the other paired SIMM slots: J104/J105, J106/J107, J108/J109, and J110/J111.

Install the new SIMM card pairs into the next adjacent empty connector pairs on the system card.

5. Install the system card into the back of the system unit cabinet by following the procedure described in Step 8 of “Replacing the System Card”.

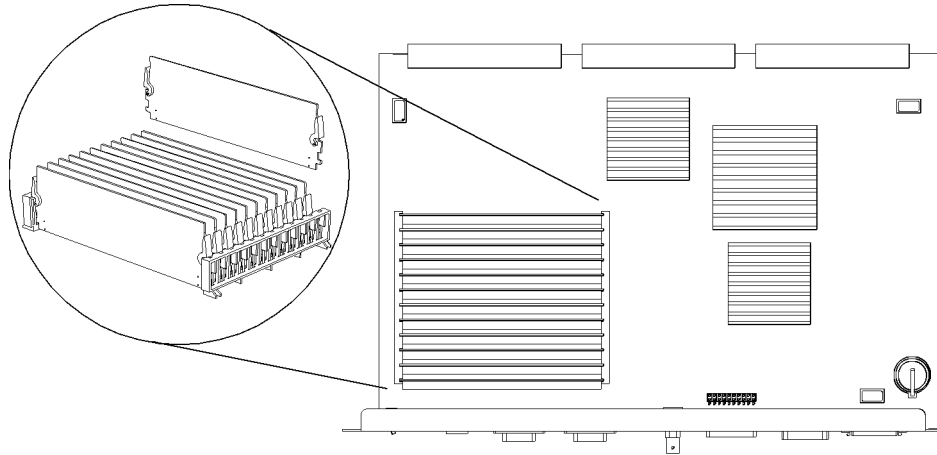

Figure 5-4. SIMM Card Removal/Replacement/Addition

Replacing the Lithium Battery

The lithium battery provides power for the system clock and stable storage. It is located on the system card.

Caution There is danger of explosion if this battery is not replaced correctly. Replace this battery *only* with Panasonic BR-2325 or equivalent. Discard the used battery according to the battery manufacturer's instruction.

Perform the following steps in the order given to replace the lithium battery:

1. Shut down the system as described in “Getting Ready” earlier in this chapter.
2. Power down the computer and all its peripherals, and disconnect the power cord from the system unit.
3. Remove the system card from the middle slot of the system unit cabinet as shown in Figure 5-3. Note the location of the lithium battery and its holder (see Figure 5-5).
4. Remove the used battery by sliding it from beneath the metal spring clip that holds it in place.
5. Making sure that the *positive (+)* side of the replacement battery is *up*, slide it into place underneath the metal spring clip.
6. Re-install the system card into the middle slot of the system unit cabinet.

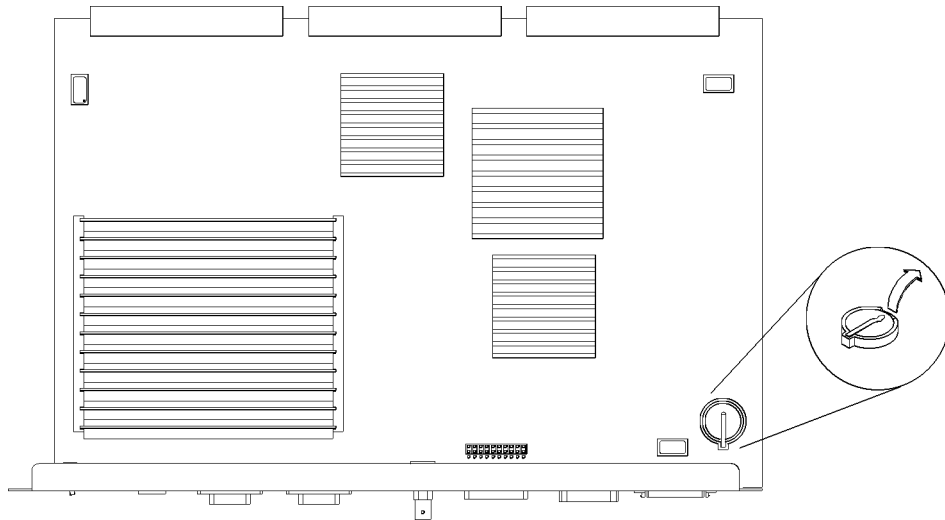

Figure 5-5. Lithium Battery Location

Changing 802.3 LAN Types

Your computer accepts two different types of LAN connectors. Only one of the connectors on the I/O bulkhead may be used. To change connector types, you must reset some jumpers on the system card. Perform the following steps in the order given to change the 802.3 LAN type jumpers on the system card:

1. Shut down the system as described in “Getting Ready” earlier in this chapter.
2. Power down the computer and all its peripherals, and disconnect the power cord from the system unit.
3. Remove the system card from the middle slot of the system unit cabinet as shown in Figure 5-3.
4. Change the LAN type jumper settings on the system card as shown in Figure 5-6.
5. Re-install the system card into the middle slot of the system unit cabinet.

LAN Cable Connections

For thick LANs, an external MAU must be connected between the AUI port on the system bulkhead and the thick LAN cable.

For thin LANs, a “T” is used to connect the internal MAU on the system card to the BNC cables.

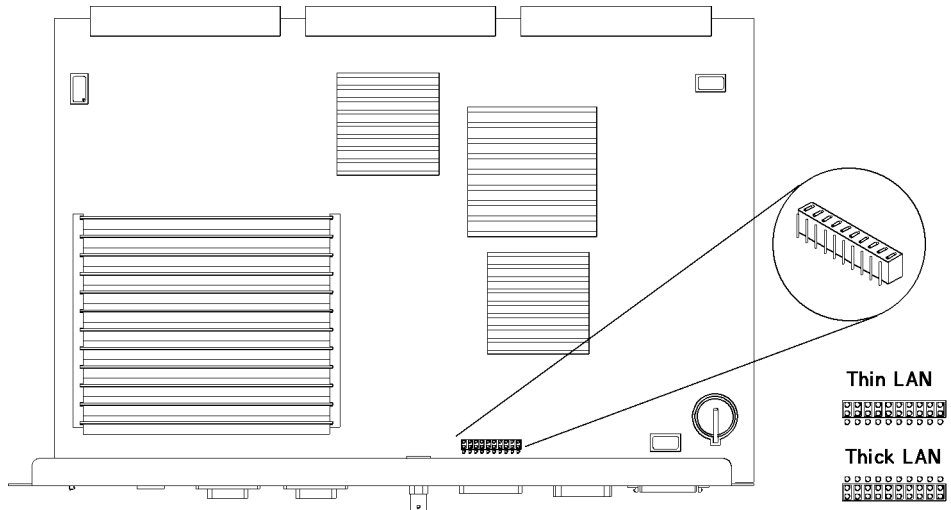

Figure 5-6. Location of the LAN Type Jumpers on the System Card

Replacing a Graphics Card

A graphics card connects your computer to video display monitor or to an external graphics processor.

Perform the following steps in the order given to replace a graphics card:

1. Shut down the system as described in “Getting Ready” earlier in this chapter.
2. Power down the computer and all its peripherals, and disconnect the power cord from the system unit
3. Disconnect any cables connected to the graphics card.
4. Remove the graphics card from its slot in the upper portion of the system unit as shown in Figure 5-7.

Note

For HP-UX 8.05, graphics slot 1 (the leftmost slot in the top section of the system unit, as viewed from the rear) is the *only* supported graphics slot. Do *not* use graphics slot 0 (the center slot in the top section of the system unit, as viewed from the rear). This slot is *not* supported for HP-UX 8.05.

5. Install another graphics card into the slot and reconnect the cable(s).

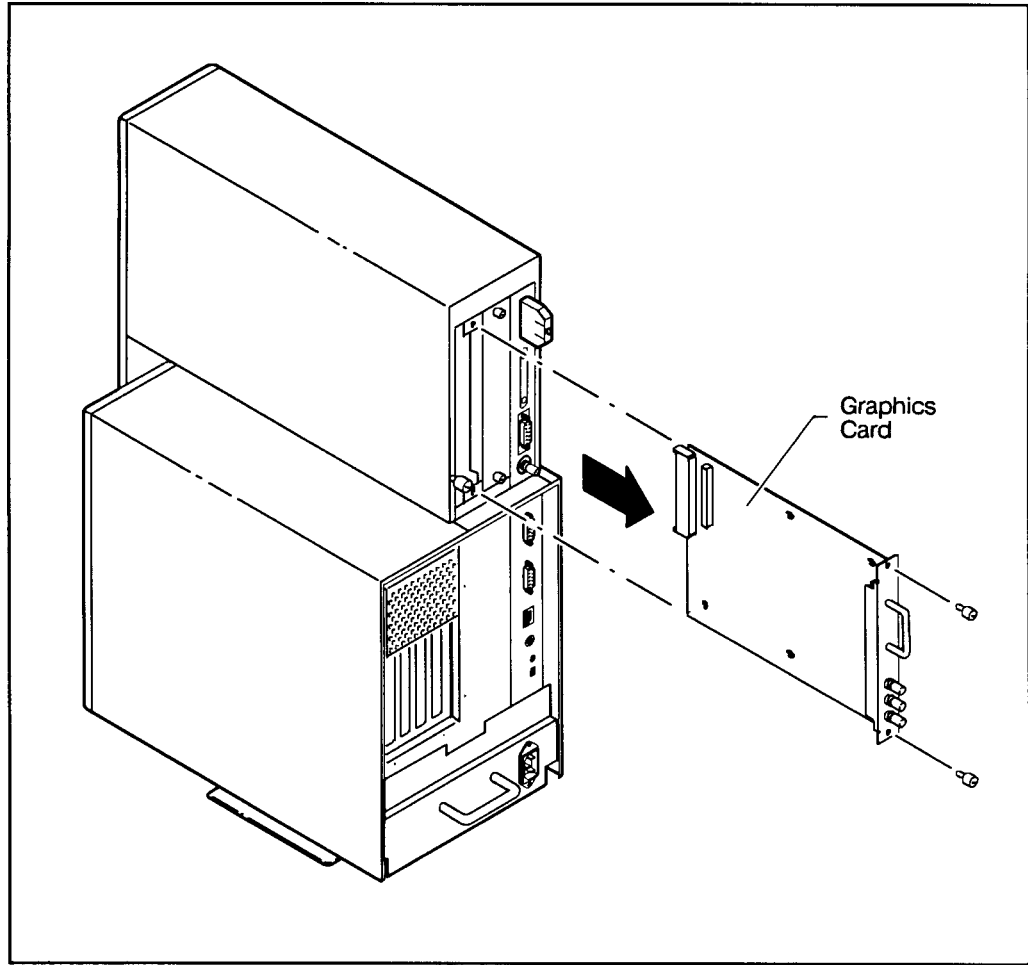

LG200183_026

Figure 5-7. Graphics Card Removal

Adding, Replacing, or Removing EISA or ISA Cards

You must refer to *E/ISA Configuration Guide for HP-UX: HP 9000 Series 700 Computers* to complete the installation of EISA or ISA cards. There may be special requirements for configuration of ISA cards.

To add or replace an EISA or ISA card:

1. Shut down the system as described in “Getting Ready” earlier in this chapter.
2. Power down the computer and all its peripherals, and disconnect the power cord from the system unit.
3. If you are replacing or removing an EISA or ISA card, disconnect any cables connected to that card.

4. Remove the top cover and the EISA card bay's outer cover as shown in Figure 5-8.

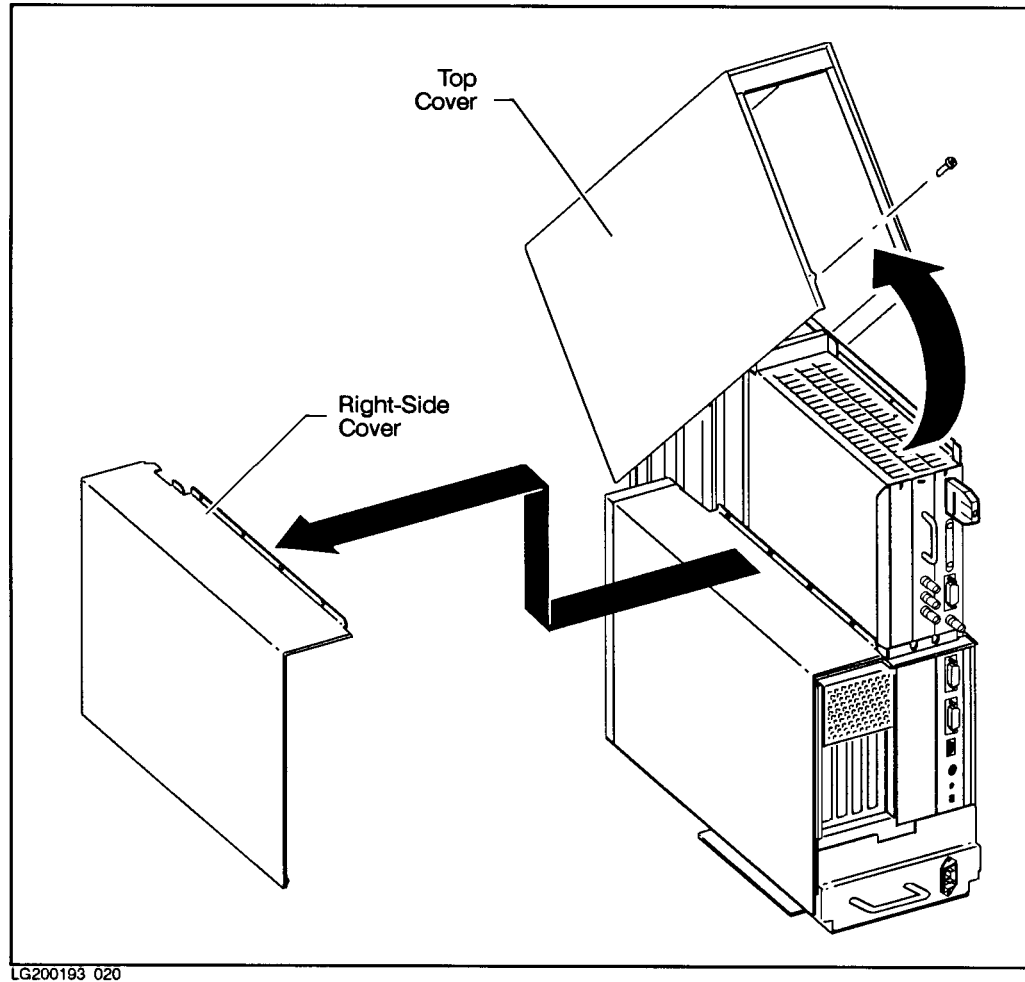

Figure 5-8. Removing the Top Cover and the EISA Card Bay's Outer Cover

5. Remove the EISA card bay's RFI (radio frequency interference) shield as shown in Figure 5-9.

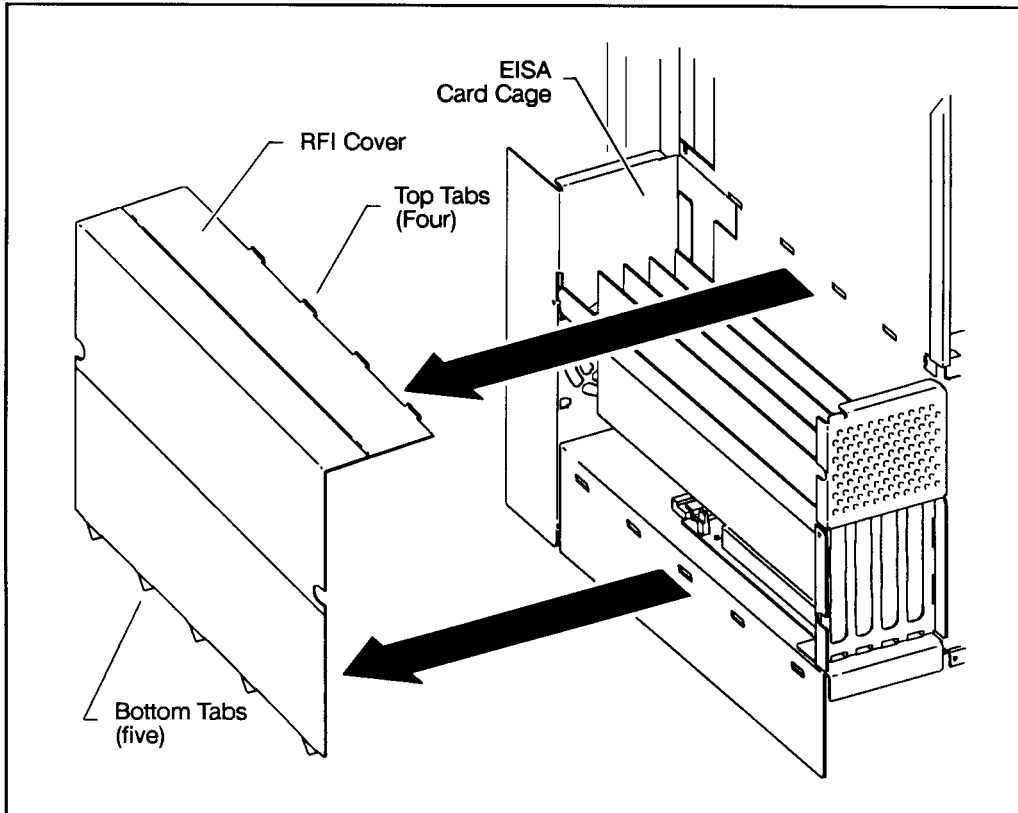
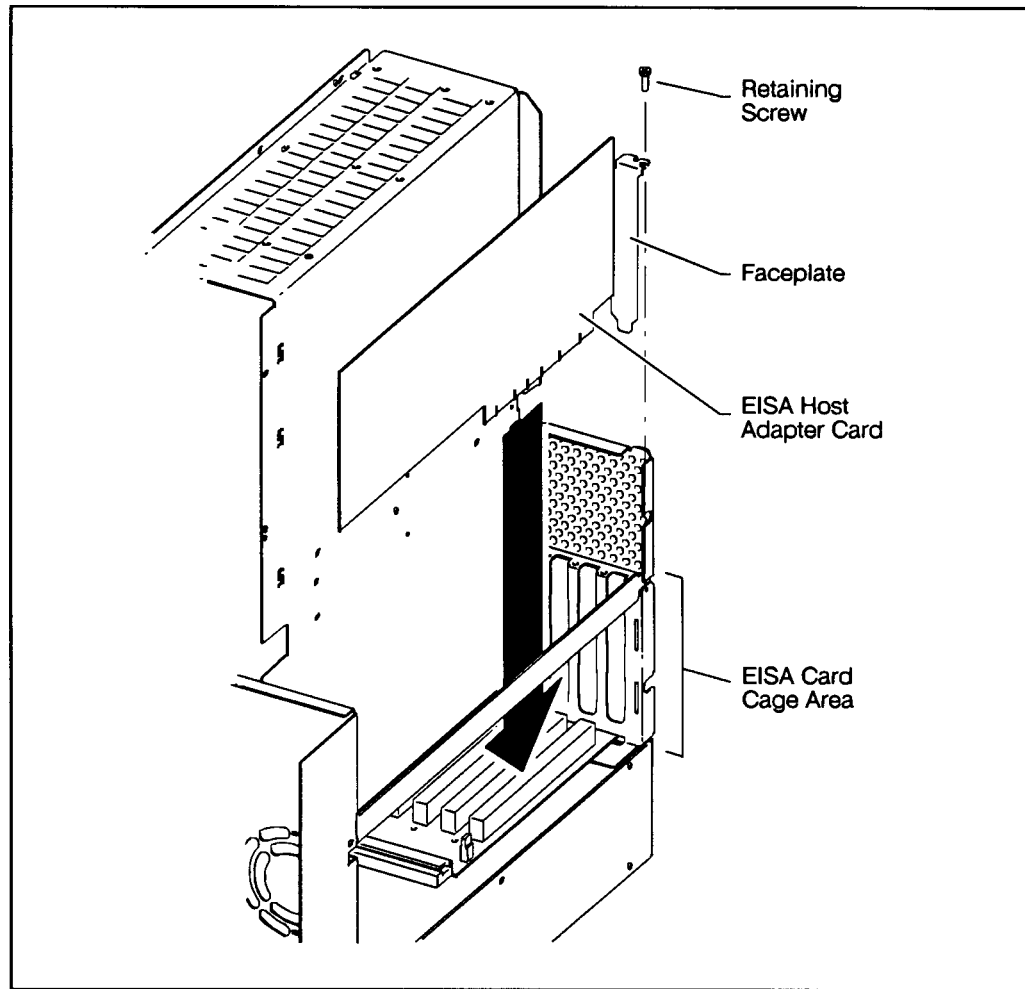

Figure 5-9. Removing the EISA Card Bay's RFI Shield

6. Remove the retaining screw from the blank faceplate (if you are adding a card) or the existing card (if you are replacing or removing a card). See Figure 5-10. Save the screw.



LG200193_022

Figure 5-10. Installing/Removing/Replacing EISA or ISA Cards

7. Remove the blank faceplate or existing card.
8. If you are removing an EISA or ISA card and *not* replacing it with another card, attach a blank faceplate to the power supply bulkhead with the screw you saved earlier. Proceed to Step 12.
9. If you are adding or replacing a card that has jumpers, switches, or other configurable parts, set the jumpers, switches or other hardware. Refer to the card's documentation for instructions.
10. Insert the new EISA or ISA card into the slot, carefully aligning the electrical contact pins on the card with the EISA slot. Press the card all the way down into the slot.
11. Secure the EISA or ISA card's faceplate to the computer chassis using the retaining screw you removed earlier.
12. Replace the EISA card bay's RFI shield and outer cover. Then replace the top cover on the system unit.
13. Follow the instructions in *E/ISA Configuration Guide for HP-UX: HP 9000 Series 700 Computers* to configure the card.

Removing an Internal Mass Storage Device

Your HP Apollo 9000 Model 750 has three bays for mass storage devices. The lower and middle bays may contain one full-height device each. Supported full-height devices include hard disks and a DDS-format tape drive. The top bay may contain one full-height device or either one or two half-height devices. Supported half-height devices include a microfloppy disk and a CDROM drive.

Procedures for removing these devices varies slightly if the devices are full-height or half-height units.

Removing a Full-height Device

Perform the following steps in the order given to remove a full-height internal mass storage device:

1. If the mass storage unit is a hard disk drive, back up the data it contains with `fbackup`.
2. If you plan to replace this mass storage unit with an *identical* device, proceed to Step 3.

If you are *permanently* removing this unit and *not* replacing it with an identical unit, or if you are replacing this unit with a unit of a different type, remove the disk using SAM (the System Administration Manager):

- a. Type:

```
$ /usr/bin/sam
```

- b. When the System Administration Manager menu appears, select the following sequence of screens by moving the highlight bar with the **▲** or **▼** keys and pressing the **Select Item** softkey:

```
Peripheral Devices
↓
Disk Drives -->
↓
Remove a Hard Disk Drive...
```

- c. Follow the directions on the screen labeled **Remove a Hard Disk Drive**.

- d. Return to the initial SAM menu by pressing the **Previous Menu** softkeys.
 - e. Exit SAM by pressing the **Exit SAM** softkey.
3. Shut down the system as described in “Getting Ready” earlier in this chapter.
 4. Power down the computer and its peripherals, and disconnect the power cord from the system unit.
 5. Disconnect from the system bulkhead the cables to any external SCSI devices. If there is a terminator on the system bulkhead’s SCSI connector, remove it and set it aside.

6. Remove the thumbscrew from the back of the system unit's top cover. Remove the top cover. If you intend to remove a mass storage unit from either of the lower bays, remove the left side cover as well. (See Figure 5-11.)

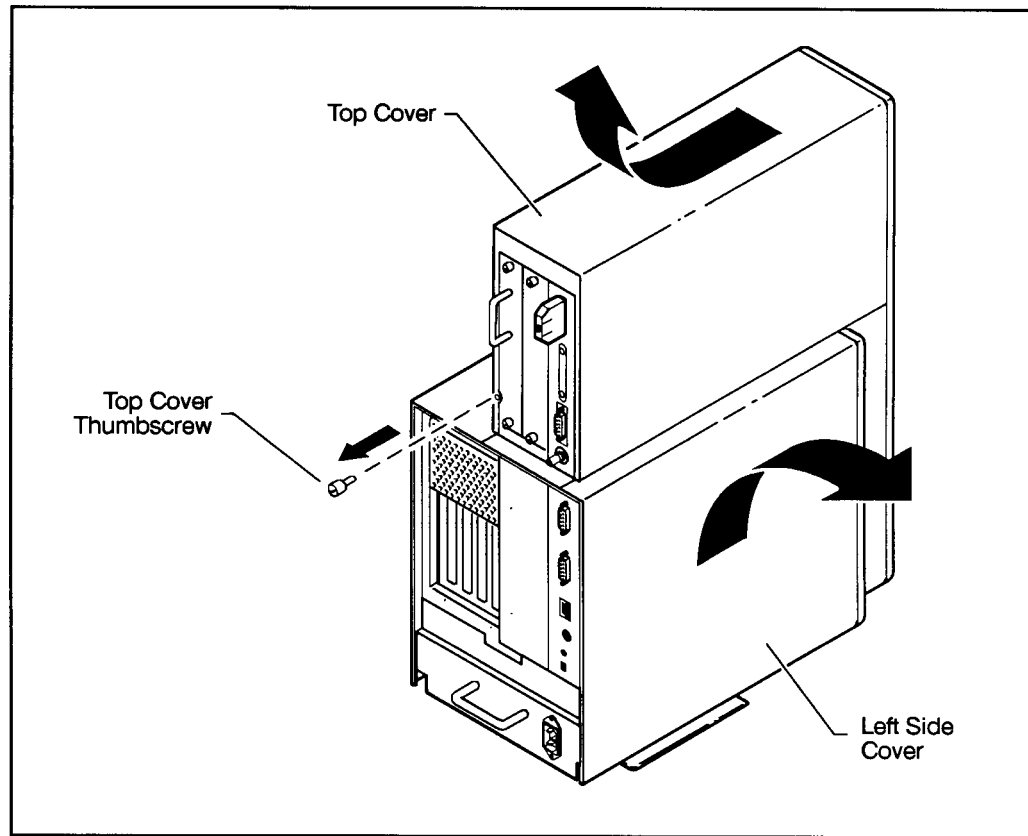

LG200193_012

Figure 5-11. Removing the Top Cover and the Left Side Cover

7. If you intend to remove a mass storage unit from either of the lower bays, remove the small cover on the lower right side of the central section of the system unit. (See Figure 5-12.)

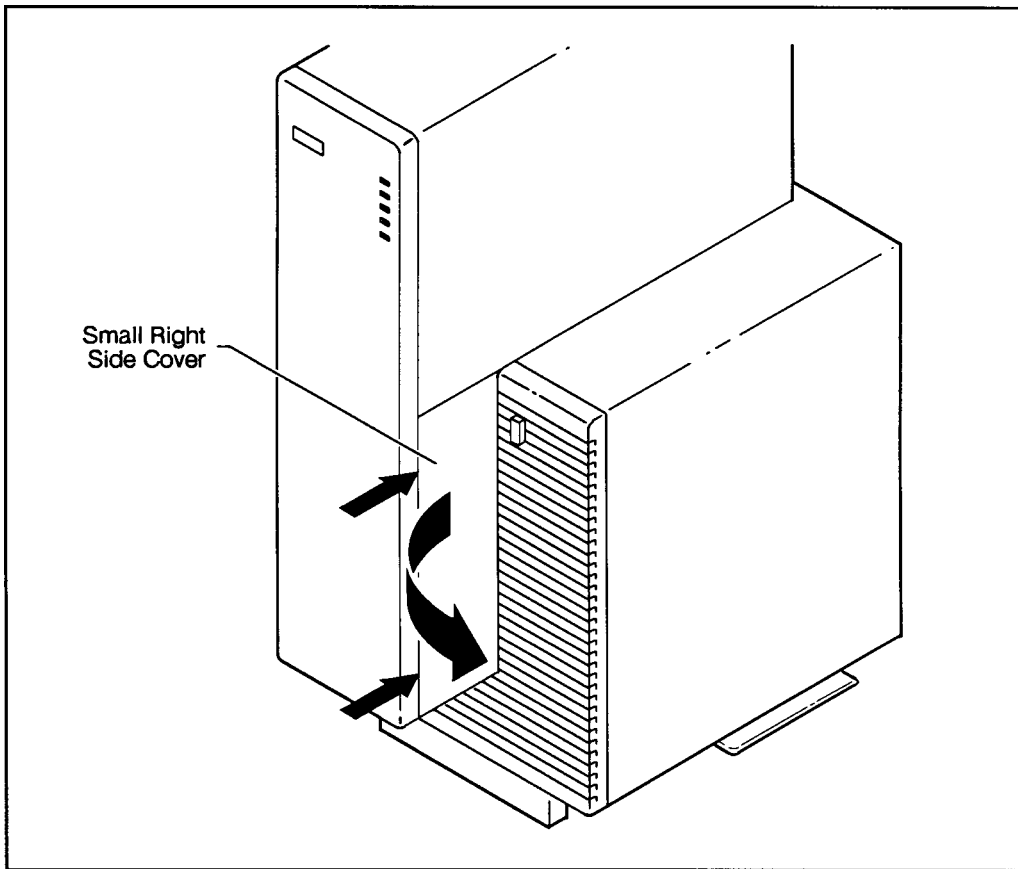

LG200193_013

Figure 5-12. Removing the Small Cover

8. Remove the screws that hold in place the mounting bracket which contains the mass storage unit you are going to remove. (See Figure 5-13.)

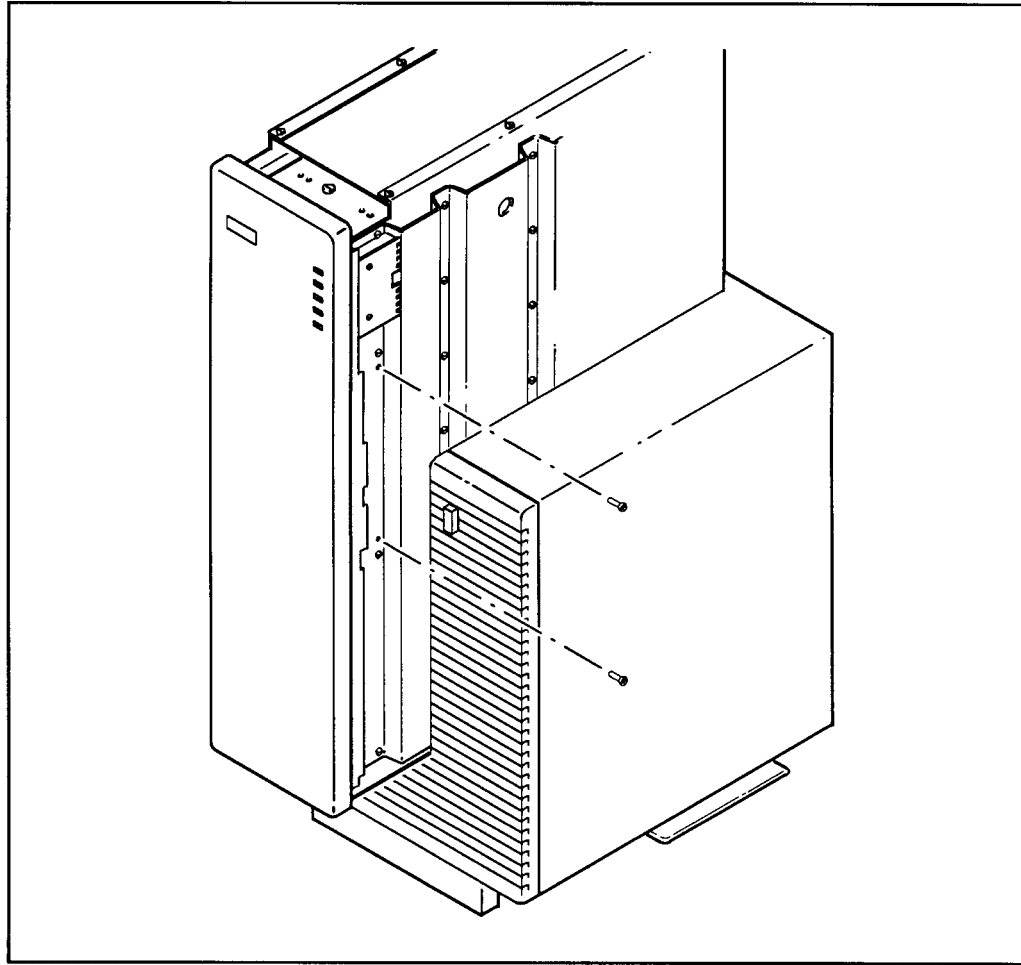

LG200193_014

Figure 5-13. Removing Screws from the Mounting Bracket

9. Locate the access plate for the mass storage unit you are going to remove. Remove the retaining screw from the access plate. Remove the access plate. (See Figure 5-14.)

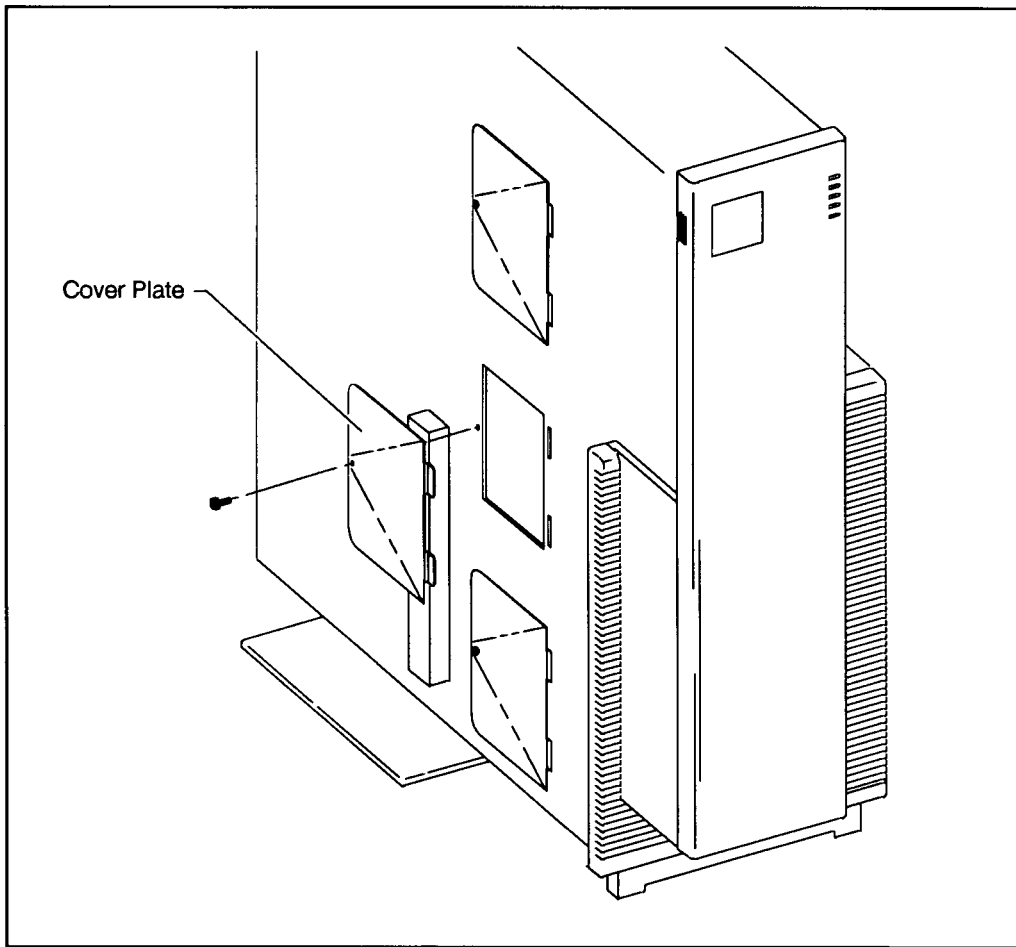

LG200193_015

Figure 5-14. Removing the Access Plate

10. Open the front door of the system unit. Remove the trim above and/or below the mass storage unit you are going to remove. (See Figure 5-15.)

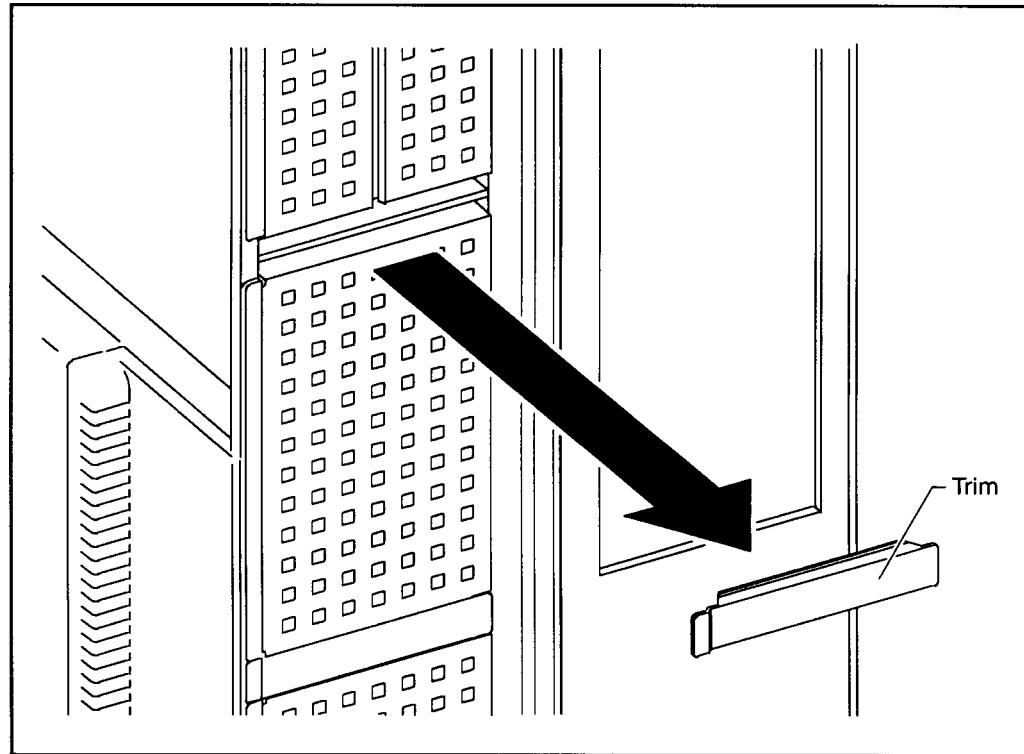

LG200193_016

Figure 5-15. Removing the Trim

11. Slide the mounting bracket a short distance forward. Working through the access opening, detach the SCSI and power cables from the mass storage unit. Pull gently on the connectors, *not* on the cables. Attach the cables to the clip in the back of the bay.

12. Slide the mounting bracket completely out of the bay. (See Figure 5-16.)

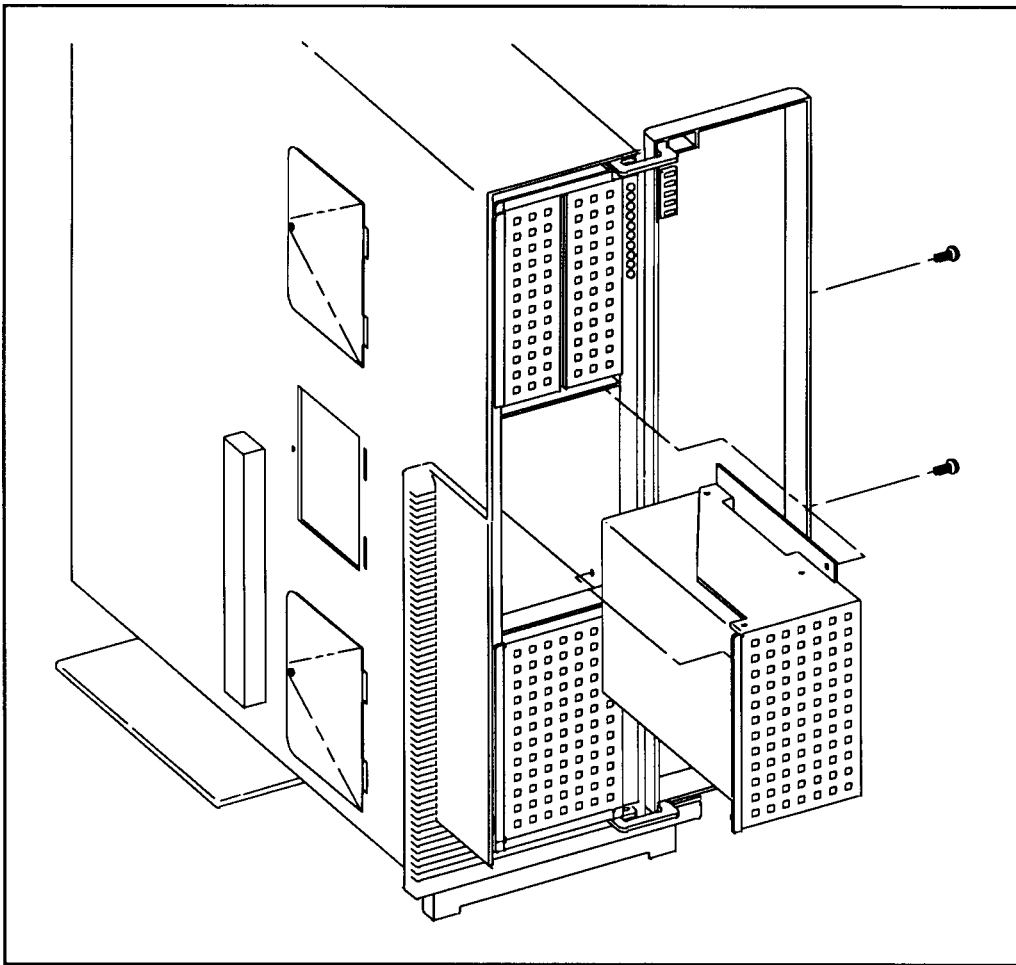

LG200193_017

Figure 5-16. Removing the Mounting Bracket

13. Remove the mass storage unit from the mounting bracket. (See Figure 5-17.)

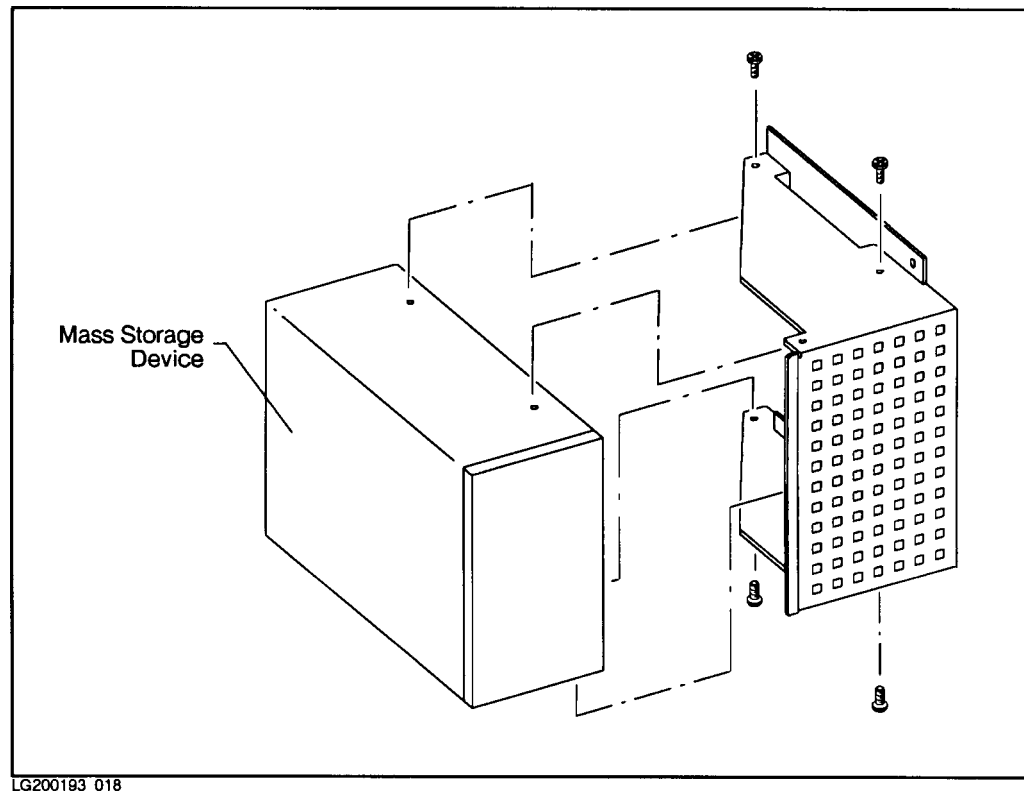

Figure 5-17. Removing the Mass Storage Unit from the Mounting Bracket

Caution Handle the mass storage unit carefully! It may be sensitive to static electricity or mechanical shock. Follow all ESD precautions listed in “Electrostatic Discharge (ESD) Precautions” earlier in this chapter.

14. Install the mounting bracket back into the system unit cabinet and reconnect the SCSI cables/terminator to the system bulkhead.

Note One SCSI terminator must always be installed at the end of the last external device. The internal SCSI cable already has a terminator built in.

15. Reconnect the power cable.

Removing a Half-height Device

The top bay may hold one or two half-height mass storage devices. It may also hold one full-height device, or it may remain empty.

Removing a half-height device is very similar to removing a full-height device. There are these differences:

- Half-height devices can be placed only in the top bay.
- Only the top cover need come off the system unit. It is not necessary to remove the left side cover or the small cover on the lower right side of the central section of the system unit.

- The mounting bracket for half-height devices differs in appearance from the bracket for full-height devices. (See Figure 5-18.)

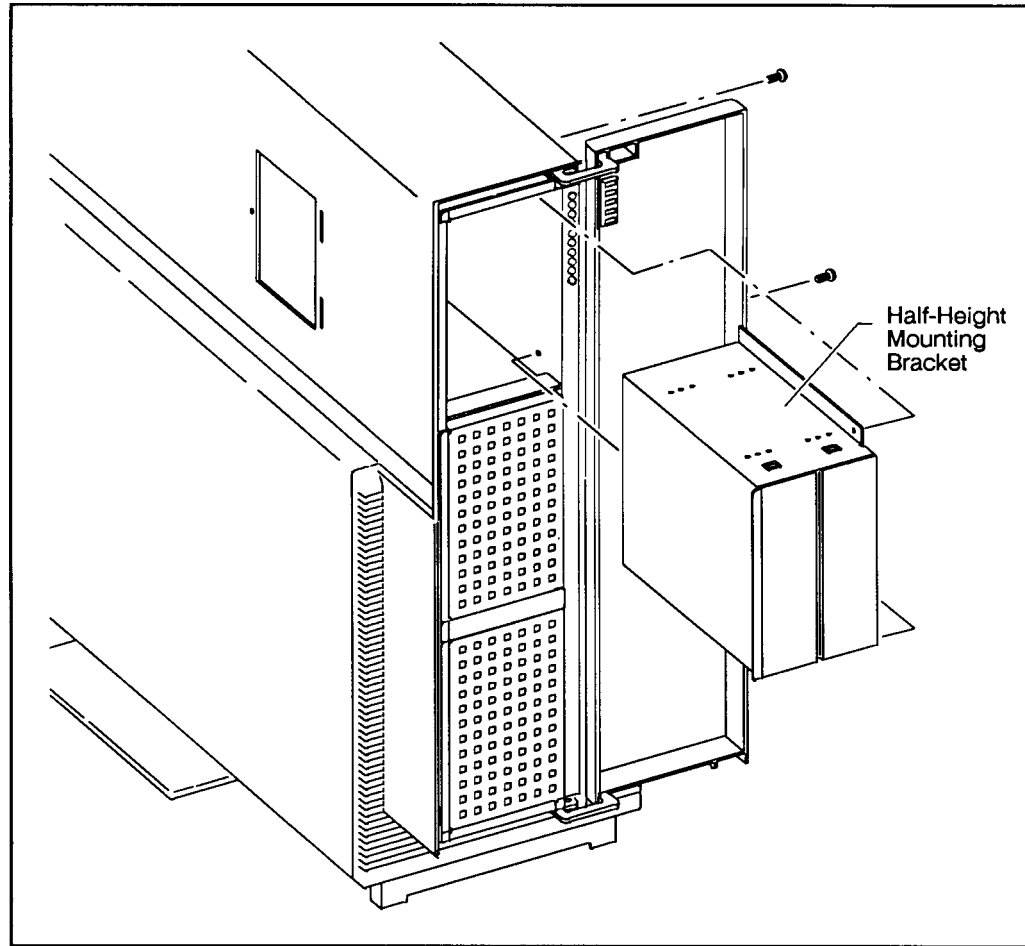

LG200193_019

Figure 5-18. Removal of a Half-height Internal Mass Storage Device

Replacing the Power Supply

You cannot replace the power supply on your HP Apollo 9000 Model 750 yourself. Contact your designated service representative for assistance.

Troubleshooting

This chapter contains information that will help you determine what's wrong with your system when you have problems.

Your system comes with many tools to help you understand operating faults:

- Front panel LEDs
- Power-on selftests
- Boot Administration commands
- System Acceptance Test

You will learn how and when to use these resources in this chapter.

Troubleshooting Strategies

This is an outline of what you should do in the event of trouble.

1. If you turn on the power, and your computer is completely unresponsive (the *green-colored* LED on the front panel is not ON and nothing appears on the monitor for more than 20 seconds), see “System Unresponsive”.
2. If the computer responds, but the operating system does not begin loading, see “Operating System Will Not Load”.
3. If the operating system loads, but the system *hangs* (if it is no longer responsive to input from the keyboard or mouse, and the cursor stops flashing or disappears) or the system works intermittently, see “System Loses Network Communications”.
4. If your computer has a *hard crash* (stops working altogether and displays an **HPMC error**), call your designated service representative. An HPMC error is an unrecoverable hardware error, and it may require the use of special

diagnostic tools and replacement of a hardware component which you cannot access.

5. If your computer cannot be turned *off*, call your designated service representative. This requires replacement of a hardware component which you cannot access.

System Unresponsive

Try the actions listed in Table 6-1 if your system does *nothing* in response to turning on the power.

Table 6-1. Problems with Powering Up the System

Problem	Action
The power LED doesn't come on.	Make sure the AC power cable is connected securely to the system unit. Make sure the power cord is plugged into a working AC outlet. Make sure the power on/standby switch is set to the ON position. Depress it several times to see if the system can be made to respond.
None of the <i>amber-colored</i> LEDs in the front panel turn ON after the power switch is depressed.	Replace the power supply. See "Replacing the Power Supply" in Chapter 5.

6-2 Troubleshooting

Operating System Will Not Load

Try the actions listed in Table 6-2 if the operating system will not begin loading.

Table 6-2. Problems with Loading the Operating System

Problem	Action
The <i>green-colored</i> power LED is on, but the screen is blank or is flickering.	If your system is equipped with an external graphics unit, make sure that its power switch is set in the ON position. Use the Brightness control on the monitor to increase the brightness level. If the screen is still blank, turn off the power switches. When the power LED goes off, check the video cable connections.
The <i>green-colored</i> power LED is <i>not</i> ON, but the <i>amber-colored</i> LEDs are ON.	Replace the power supply. See “Replacing the Power Supply” in Chapter 5.
The power LED is ON, and text has appeared on the screen, but more than two minutes have passed without any sign of disk activity.	Check all SCSI cables and the SCSI terminator to make sure that they are correctly routed, connected, and secured. Consult <i>Installation Guide for HP Apollo 9000 Model 750 Workstations and Servers</i> for information on cable connections for your SCSI devices.
System still won't boot.	Examine the eight <i>amber-colored</i> LEDs (see Figure 6-1). Make a note of the pattern displayed by these indicators. Press the TOC switch. (See Figure 1-5 for the location of this switch.) This should cause the system to reboot (restart the HP-UX operating system).
System does not boot.	See “Dealing with a Boot Failure” later in this chapter.

System Loses Network Communications

If the program you have been running uses resources from a local area network, and it stops unexpectedly, see Table 6-3.

Table 6-3. Problems with the 802.3 Network

Problem	Action
No systems respond to the <code>/etc/ping</code> command.	Check the network connection at the back of your computer. Make sure that the cable is securely fastened to the appropriate connector.
Your system does not respond to <code>/etc/ping</code> from another system on the network.	Check to see if the networking software is still running on your system. If it is not running, restart it by logging onto your system as superuser and running <code>/etc/rc</code> .
Some systems respond to <code>/etc/ping</code> , but others do not.	Contact the network administrator immediately. This condition most probably indicates a serious fault with the network. Contact the network administrator.

System Works Intermittently

If your system works intermittently, see Table 6-4.

Table 6-4. Intermittent Failures

Problem	Action
Parts of the system seem to work, but others do not.	Run the SAX tests to verify that the system's hardware is functioning properly. (See the section "Running the SAX (System Acceptance Executive) Tests" in this chapter.)
The hardware passes the SAX tests, but operation is still intermittent.	Call your designated service representative.

Dealing with a Boot Failure

If you have reached this section, your usual boot device (typically a disk) is not responding as it should. You must attempt to boot from the disk (or another boot device) by selecting it manually.

To boot a device manually, follow these steps:

1. Turn off the power to the computer, wait a few seconds, then turn the power back on.
2. Press the `(Escape)` key. In a few seconds, this message appears:

```
Terminating selection process.
```

A short time later, this message appears:

```
Searching for potential boot devices.  
To terminate search, press and hold the ESCAPE key.
```

```
Device Selection Device Path Device Type and Utilities  
-----
```

Your computer is now searching for devices that *may* hold file systems from which it can boot HP-UX. As they are found, they appear in a list.

A list of devices might look like this:

```
P0                scsi.6.0                Disk_drive_identifier  
P1                scsi.5.0                Disk_drive_identifier  
P2                scsi.4.0                DDS-format_tape_drive_identifier  
P3                scsi.3.0                CD_ROM_drive_identifier  
P4                lan.123456-789abc        cluster_server_hostname
```

This process may take several minutes. You can terminate the search at any time by pressing `(Escape)`. When the search ends, this list of actions appears:

```
b) Boot from specified device  
s) Search for bootable devices  
a) Enter boot administration mode  
x) Exit and continue boot sequence  
?) Help
```

```
Select from menu:
```

- If *no* devices are listed, there is a serious problem. Contact your designated service representative for assistance.

6-6 Troubleshooting

- If no disk devices are listed, then your computer is failing to communicate with its disks. Recheck the SCSI connections and try again.
3. If the search locates the disk that contains your root file system, attempt to boot from it. Enter the boot command (**b**) with your choice from among the listed devices. For example, if a SCSI disk is listed as item **PO** (as in the example list above), type:

Select from menu: b PO

It may be several seconds before the boot messages begin to appear on the screen. You may hear sounds coming from the disk drive and see a sequence of changing patterns on the LED display.

If you see several disks in the list, but you do not know which among them can be booted from, type:

Select from menu: s

The system will conduct another search which will list *only* those devices which contain bootable media. Boot from one of these.

4. If your computer still fails to boot, there is either something wrong with the file system or with the hardware. If you suspect a file system failure, see “Dealing with File System Failures” later in this chapter. If you think that something is wrong with the hardware, see “Dealing with Hardware Faults”. If you are not certain, continue with the next section.

Dealing with File System Failures

If you have reached this section, it is very probable that your filesystem has been **corrupted** (damaged). Don't panic! There are ways to recover your filesystem, at least to the point of being able to start your system.

- If you are trying to get your system started for the first time, and you have reached this point, you must recover your file system from a Support Medium. See “Using a Support Medium to Recover Your File System” for instructions.
- If you have created a recovery system (as described in “Creating a Recovery System” in Chapter 4) and followed the backup procedures recommended in *System Administration Tasks*, you should have no difficulty in restoring your file system with the **frecover** utility. Follow the steps in “Restoring

Your Disk(s)” to restore your basic file system, then consult *HP-UX System Administration Tasks* and the *frecover(1M)* manual page in *HP-UX Reference* to restore the rest of your files.

- If you have not created a recovery system, but you have a backup created by means of the **fbackup** utility, use the copy of **frecover** on the Support Medium to recover your file system.
- If you have not created a recovery system, but you have created image copies of your disk(s) either with **dd** (as described in “Creating a Disk Image” in Chapter 4 or with the utilities on the Support Medium (see “Using the Backup System Disks Main Menu Option”), restore your disks with the **dd** command. See the *dd(1)* manual page in *HP-UX Reference* for more information.
- If you have neither a backup created with **fbackup** nor a disk image, you must attempt to restore your system to operation by means of the utilities on the Support Medium. See “Using a Support Medium to Recover Your File System” for details.

Restoring Your Disk(s)

There are four steps to the restoration process:

1. Boot the **recovery system**. This is an abbreviated version of HP-UX that you created on tape or other media. To boot the recovery system, follow the instructions in “Booting the Recovery System” later in this section. (The procedure for *creating* a recovery system is described in “Creating a Recovery System” in Chapter 4.)

One of the first actions taken by the recovery system will be to perform a file system check with **fsck**. This may solve your disks’ problems without having to go through the rest of the procedure.

2. Back up the disks. Even if the disks are corrupted, there may be valuable data on them which might be restored. Also, the reason for the failure may be determined through an analysis of the backup.
3. Restore the files you need by using **frecover**.

6-8 Troubleshooting

Booting the Recovery System

To boot the recovery system:

1. Turn on the power to the mass storage device (a DDS-format tape drive, for example) that will hold the recovery system.
2. Insert the recovery system in the mass storage device.
3. Boot the system from the recovery system (see “Dealing with a Boot Failure”) using a command in this form:

Select from menu: `b device_path`

where *device_path* is a designator for the path to the device that contains the recovery system. For example, to boot from a DDS-format Support Medium in a tape drive located at `scsi.4.0`, type:

Select from menu: `b scsi.4.0`

You can also use the **Device Selection** identifier. For example, if the device containing the recovery system is designated as `P2`, type:

Select from menu: `b P2`

4. Over the next ten minutes, a series of messages (similar to those listed below) appears on your system’s console:

```
Trying scsi.4.0
Boot path initialized
Attempting to load IPL
```

```
Soft booted.
```

```
ISL Revision A.00.09 March 27, 1990
```

```
ISL booting hpux boot tape(;0):RECOVER
```

```
Secondary Loader 9000/700
Revision 2.1
Booting tape(;0):RECOVER
1005668 + 4505600 + 184828 start 0x23b78
```

5. A menu similar to this one appears:

6. The system will attempt to run the file-system checking command **fsck** with the **-p** (“preening”) option. If **fsck** runs successfully, you may not have to proceed further, since the file system will be in a bootable state. If **fsck** does not succeed in repairing your file system, you receive a message to that effect.

Using the Recovery System

This menu is on your screen:

- 1) Remove the root password.
- 2) Work in a shell to perform recovery manually
- 3) Perform and automatic recovery
- 4) Exit recovery system and reboot file system
- 5) Help

Selection >>

To use the recovery system:

1. Press **5** **(Return)** for information about each option on the menu.
2. If you wish to continue with the recovery process, press **3** **(Return)**. This replaces key files so that the root disk can be used again. The replaced files are saved in a directory under **/tmp**. The recovery process displays the menu when the recovery is complete.
3. To reboot your system, press **4** **(Return)**.

If your system boots successfully, and you have backup tapes containing files that should also be restored, use **frecover** to copy these files from your backup tapes. See *System Administration Tasks* and the *frecover(1M)* manual page in *HP-UX Reference* for instructions on how to restore the rest of your files.

If your system still fails to boot, see “Dealing with Hardware Faults” later in this chapter.

6-10 Troubleshooting

Using a Support Medium to Recover Your File System

The Support Media come in two forms:

- DDS-format tape
- CD ROM

The basic operations and procedures described in this section are correct for either form of the Support Media. The CD ROM has some additional features which are due to the random-access nature of this medium.

The Support Media provide the opportunity to diagnose and fix system problems when the operating system won't boot. Either Support Medium (DDS-format tape or CD ROM) runs with or without a properly functioning root disk.

The software recovery utilities available on the media are available for the end user to attempt to recover a file system. The remaining utilities are reserved for HP personnel only.

Note You are licensed to use only the Recovery Utilities on the S700 Support Media. The use of any other executable code on the S700 Support Media is restricted to HP personnel only. Hewlett-Packard shall not be liable for any damages resulting from unauthorized use of the S700 Support Media. The Support Media remains the property of Hewlett-Packard.

The focus of this section is on the software recovery utilities.

The Support Media contain tools that allow you to attempt to recover a corrupted system even if you do not have a recovery system or a backup from which to restore.

Hewlett Packard recommends that you create and use a recovery system (as described in “Creating a Recovery System” in Chapter 4) using the backup strategy described in *Systems Administration Tasks*.

Caution Use of these utilities may not result in the recovery of your data. The only way to be certain that your data is recoverable

is to follow the backup strategy described in *Systems Administration Tasks*.

Resource Considerations

The Support Media contain a special version of the HP-UX operating system called the Support Kernel. The Support Kernel contains a memory-based file system and functions independently of the system disk.

Prior to using one of the Support Media, you should understand these things:

- The Support Kernel requires a minimum hardware configuration to properly function. The minimum configuration consists of 16 Mbytes of memory and an I/O path to console and DDS or CD ROM drive.
- The memory-based file system is much smaller than the typical disk-based file system.
- When the memory-based file system is full, you must remove some of the existing files prior to loading any new files.
- The total memory used by the Support Kernel is approximately 6 megabytes. The remaining memory can be used to run programs.
- Any program that runs on HP-UX can run on the Support Kernel, subject to the following limitations:
 - The program cannot attempt to use swap.
 - The program cannot rely on the existence of swap.
 - The program's sticky bit cannot be set.

Booting the Support Medium

If the system cannot boot from the system disk, and you do not have a recovery system, boot the Support Medium by following these steps:

1. Turn on the device (tape or CD ROM drive) that will hold the Support Medium.
2. Insert the Support Medium into the device.
3. Boot the system from the Support Medium (see "Dealing with a Boot Failure") using a command in this form:

6-12 Troubleshooting

Select from menu: b *device_path* isl

where *device_path* is a designator for the path to the device that contains the Support Medium. For example, to boot from a DDS-format Support Medium in a tape drive located at `scsi.4.0`, type:

Select from menu: b `scsi.4.0` isl

You can also use the **Device Selection** identifier. For example, if the device containing the Support Medium is designated as P2, type:

Select from menu: b P2 isl

This command boots the **Initial System Loader (ISL)**; sometimes referred to as the **IPL**.

4. After the ISL> prompt appears, boot the Support Kernel:

```
ISL> support 
```

5. Several boot and initialization messages appear on the screen. Press following the prompt:

```
Press  to continue
```

The SUPPORT TAPE MAIN MENU appears. Now, you are ready to use the Support Kernel.

Caution

Do not reboot the system while any disk-based file systems are mounted. Unmount all of the disk-based file systems by typing the following:

```
# /etc/umount -a
```

There are two proper ways to reboot the system. One of them is to type the following:

```
# /etc/reboot
```

Another way is to select the **Reboot System** option from the SUPPORT TAPE MAIN MENU.

Using the Support Kernel

After you boot the Support Kernel, the following menu appears:

SUPPORT TAPE MAIN MENU

- s. Search for a file
- l. Load a file
- d. Diagnostic Menu
- h. Help Menu
- b. Backup System Disk(s)
- r. Reboot System
- x. Exit to shell

Select one of the above:

Execute a menu option by entering the associated letter and pressing **Return**. For example, exit to a shell as follows:

Select one of the above: x **Return**

Main Menu Option Definitions

- s** Specifies a file. The menu system prompts you for the name of the file you want, and then determines whether that file is on the support tape. You can specify either the file name or the full path name. If the file you want is on the tape, this selection will tell you which section of the tape the file is on.
- l** Loads the file into the memory-based file system. The menu system will prompt you for the name of the file you want to load.
- d** Goes to the Online Diagnostics Menu. This option is reserved for use by Hewlett Packard personnel only.
- h** Goes to the Help Menu. See “Support Tape Help Menu” for more details.
- b** Backup system disks. See “Using the Backup System Disks Main Menu Option” for more details.

6-14 Troubleshooting

- x Exits the menu system to the Bourne shell. To return to main menu from Bourne shell prompt, simply type “menu” followed by `Return`.

Support Tape Help Menu Option Definitions

SUPPORT TAPE HELP MENU

- i. Display Support Tape manual
- a. Display an annotated index of the files on the tape.
- m. Display a manual page for a command
- r. Return to main menu
- x. Exit to shell

Select one of the above:

Help Menu Options.

- i Displays this manual at the terminal using the **more** command.
- a Display an annotated index of the files on the tape.
- m Display a detailed description of a specific command. You are prompted for the name of the command you want to know about.
- r Return to main menu.
- x Exit to shell.

Using the Backup System Disks Main Menu Option

This Main Menu option allows you to create a raw backup of current contents of system disk(s). Disk images are backed up on a DDS tape in 10 kilobyte block sizes. Multiple disk images on the same tape are separated by `End_Of_File` (EOF) marks. Remember, this backup process creates disk “images” using the `dd` command (see `dd(1)` in *HP-UX Reference*). Therefore, when the DDS tape is used to recover a disk, you will need to use `dd`. If you wish to make a more traditional backup, please use `fbackup`. Both `fbackup` and `frecover` are available on the Support Medium.

Obtain a DDS tape which may be written on without destroying needed data. Make sure that the tape is not write-protected. To do this, check the rear of the cassette. You will see a sliding tab in one corner. This tab is used to open and close the "recognition hole" in the cassette. If the hole is open, the cassette is write-protected; if it is closed, data may be written on the tape. If necessary, slide the tab to close the recognition hole.

Once you have selected the backup option from the Main menu, you may create backups as follows:

1. Respond to the following prompt with the drive path of the medium upon which the backup will be created. If you are currently booted from a DDS-format tape drive, you will most likely use the same path that you booted from.

```
Legal tape drive paths :
    SCSI.0.0, SCSI.1.0, SCSI.2.0, SCSI.3.0,
    SCSI.4.0, SCSI.5.0, SCSI.6.0, SCSI.7.0
```

Enter Tape Drive Path:

For example, to select the available DDS drive, from the earlier example, enter:

```
Enter Tape Drive Path: SCSI.4.0 
```

2. If you booted from DDS tape, you are now prompted to remove the Support Tape and insert the tape upon which the disk image will be created.

```
Remove Support Tape from tape drive.
Insert writable scratch tape into tape drive.
```

If you booted from a CD ROM or have inserted the backup tape, you now see:

```
Press "c" then <return> to continue, or
press "a" then <return> to abort backup process.
```

If you chose to continue and the tape is write protected, you see the message:

```
Unable to access tape at <address> for writing.
Insert writable scratch tape into tape drive.
```

6-16 Troubleshooting

Press "c" then <return> to continue, or
press "a" then <return> to abort backup process.

If you receive this message, remove the tape and close its write-protect tab.
Put it back in the tape drive, and press **C** **return**.

If you choose to abort the backup process (by pressing **A** **Return**), you see a
prompt that allows you to return to the Main Menu.

3. If you chose to continue the backup, you now see the following:

Legal tape drive paths :
SCSI.0.0, SCSI.1.0, SCSI.2.0, SCSI.3.0,
SCSI.4.0, SCSI.5.0, SCSI.6.0, SCSI.7.0

Enter Tape Drive Path of the Volume to be Backed Up:

If you wish to backup the disk at SCSI address 6, type:

Enter Tape Drive Path of the Volume to be Backed Up: SCSI.6.0

When the backup is finished, you see:

Press "u" then <Return> to back up another volume.
Press "a" then <Return> to abort backup process.

4. Take one of the following actions:
 - a. Type **U** **Return** to see the previous menu to specify the volume to be backed up. Repeat the instructions above for each disk image you make.
 - b. Type **A** **Return**. You see this message:

Remove scratch tape.
Insert Support Tape.
Press <return> to get back to main menu

Remove the tape from the drive, and put it in a safe place. Put the
Support Tape back in the drive, and press **return**. The SUPPORT TAPE
MAIN MENU reappears.

Note The following procedure for restoring a backup, created
by the process described above, assumes that a device file
/dev/rmt/0mn corresponds to a DDS tape drive; and device

files `/dev/rdisk/6s0` and `/dev/rdisk/5s0` correspond to the `/` (root) and `/usr` disk drives, respectively.

You must choose a device file of the “no-rewind” type for the DDS drive for this procedure to work properly. The `/dev/rmt/0mn` device file is of this type. The `/dev/rmt/0m` device file is not.

Load the backup tape into the tape drive. Type the following commands at a shell prompt:

```
# dd if=/dev/rmt/4mn of=/dev/rdisk/6s0 bs=10k
# dd if=/dev/rmt/4mn of=/dev/rdisk/5s0 bs=10k
```

Commands

You must use appropriate device files when executing HP-UX commands. All device files that you may need are already available on the Support Media. The following convention for mapping disk device file names to physical hardware paths is used by the Support Kernel:

SCSI.0.0	<code>/dev/rdisk/0s0</code> <code>/dev/dsk/0s0</code>
SCSI.1.0	<code>/dev/rdisk/1s0</code> <code>/dev/dsk/1s0</code>
SCSI.2.0	<code>/dev/rdisk/2s0</code> <code>/dev/dsk/2s0</code>
SCSI.3.0	<code>/dev/rdisk/3s0</code> <code>/dev/dsk/3s0</code>
SCSI.4.0	<code>/dev/rdisk/4s0</code> <code>/dev/dsk/4s0</code>
SCSI.5.0	<code>/dev/rdisk/5s0</code> <code>/dev/dsk/5s0</code>
SCSI.6.0	<code>/dev/rdisk/6s0</code> <code>/dev/dsk/6s0</code>

For example:

```
# /etc/fsck -p /dev/rdisk/6s0
```

This command attempts to fix the filesystem of the mass storage device located at SCSI address 6 (SCSI.6.0).

6-18 Troubleshooting

Note

Three mount points are provided in the Support kernel memory-based file system for mounting disk-based file systems. Mount points are simply empty directories that can be used for mounting file systems. These mount points are : `/mnt1`, `/mnt2`, and `/mnt3`.

For example, to mount a file system pointed at by a device file `/dev/dsk/6s0`, type the following command at the shell prompt:

```
# /etc/mount /dev/dsk/6s0 /mnt1
```

A file system may have to be fixed by `/etc/fsck` before it can be mounted. Refer to manual pages for `mount(1)` and `fsck(1)` in *HP-UX Reference* for more details.

Default Memory-based Root File System

These files are distributed on the Support Media. They are loaded into the memory-based file system from the Support Media automatically. The list of files that are automatically loaded may change. You may verify that a particular file is memory resident by using the **s** option from the main menu.

```
./profile      .bin           ./bin/cat
./bin/cp       ./bin/cpio     ./bin/dd
./bin/expr     ./bin/ls       ./bin/mt
./bin/mt       ./bin/rm       ./bin/sh
./bin/stty     ./bin/su       ./bin/tar
./dev          ./etc          ./etc/fbackup
./etc/frecover ./etc/fscck    ./etc/init
./etc/mkfs     ./etc/mknod    ./etc/mount
./etc/reboot   ./etc/umount   ./etc/passwd
./etc/group    ./etc/mnttab   ./etc/utmp
./lib          ./lib/crt0.o   ./lib/dld.sl
./lib/libc.sl  ./lib/libm.sl  ./mnt1
./mnt2         ./mnt3         ./tmp
./usr          ./usr/bin      ./usr/bin/clear
./usr/bin/tabs ./usr/bin/tset ./usr/lib
./usr/lib/terminfo ./usr/lib/terminfo/h ./usr/lib/terminfo/h/hp
./usr/tmp      ./usr/tape_ui  ./usr/tape_ui/backup_disks
./usr/tape_ui/menu ./usr/tape_ui/reboot_system ./usr/tape_ui/restor_disk
./lost+found
```

HP-UX Directory Files. These files are distributed on the Support Media. They can be loaded into the memory-based file system from the Support Media using the **l** option from the main menu. The list of files that are provided on the Support Media may change. You may verify that a particular file is on the media by using the **s** option from the main menu.

<code>./usr/diag/bin/CDUIF000</code>	<code>./usr/diag/bin/CSERV000</code>	<code>./usr/diag/bin/DIAGINIT</code>
<code>./usr/diag/bin/DIAGMON</code>	<code>./usr/diag/bin/DUI</code>	<code>./usr/diag/bin/DUIDIR</code>
<code>./usr/diag/bin/DUI10H</code>	<code>./usr/diag/bin/DIAGLIST</code>	<code>./usr/diag/bin/IODEVACC</code>
<code>./usr/diag/bin/SECURITY</code>	<code>./usr/diag/bin/libdiags.l.sl</code>	<code>./usr/diag/bin/C0000000</code>
<code>./usr/diag/bin/C0001000</code>	<code>./usr/diag/bin/C0002000</code>	<code>./usr/diag/bin/C0003000</code>
<code>./usr/diag/bin/C0004000</code>	<code>./usr/diag/bin/C0005000</code>	<code>./usr/diag/bin/C0006000</code>
<code>./usr/diag/bin/C0007000</code>	<code>./usr/diag/bin/C0008000</code>	<code>./usr/diag/bin/CARTDIAG</code>
<code>./usr/diag/bin/DASSDIAG</code>	<code>./usr/diag/bin/HPIBEISA</code>	<code>./usr/diag/bin/LANDAD</code>
<code>./usr/diag/bin/HENDIAG</code>	<code>./usr/diag/bin/SCSICD</code>	<code>./usr/diag/bin/SCSIDDS</code>
<code>./usr/diag/bin/SCSIDSK2</code>	<code>./usr/diag/bin/SYSHAP</code>	<code>./usr/diag/bin/libcl.sl</code>
<code>./usr/diag/bin/dld.sl</code>	<code>./usr/diag/bin/libc.sl</code>	<code>./usr/diag/bin/libm.sl</code>
<code>./usr/diag/bin/ipcrm</code>	<code>./usr/diag/bin/ipcs</code>	<code>./usr/diag/bin/kill</code>
<code>./usr/diag/bin/ps</code>	<code>./usr/contrib/bin/analyze</code>	<code>./usr/lib/terminfo/h/hp2392a</code>
<code>./usr/lib/terminfo/h/hp2393a</code>	<code>./usr/lib/terminfo/h/hp2394a</code>	<code>./usr/lib/terminfo/h/hp2397a</code>
<code>./usr/lib/terminfo/h</code>	<code>./usr/lib/terminfo</code>	<code>./bin/cat</code>
<code>./bin/chmod</code>	<code>./bin/chown</code>	<code>./bin/cmp</code>
<code>./bin/cp</code>	<code>./bin/cpio</code>	<code>./bin/date</code>
<code>./bin/diff</code>	<code>./bin/du</code>	<code>./bin/echo</code>
<code>./bin/env</code>	<code>./bin/false</code>	<code>./bin/find</code>
<code>./bin/grep</code>	<code>./bin/kill</code>	<code>./bin/lm</code>
<code>./bin/lis</code>	<code>./bin/mkdir</code>	<code>./bin/mv</code>
<code>./bin/nohup</code>	<code>./bin/od</code>	<code>./bin/passwd</code>
<code>./bin/ps</code>	<code>./bin/pwd</code>	<code>./bin/rm</code>
<code>./bin/size</code>	<code>./bin/stty</code>	<code>./bin/su</code>

./bin/sync	./bin/touch	./bin/true
./bin/uname	./bin/wc	./bin/nm
./bin/sum	./bin/xd	./bin/tty
./bin/tar	./bin/sh	./bin/dd
./bin/mt	./bin/expr	./etc/fsck
./etc/chroot	./etc/mkfs	./etc/mknod
./etc/mount	./etc/reboot	./etc/umount
./etc/init	./etc/swapon	./etc/clri
./etc/devnm	./etc/dmesg	./etc/fbackup
./etc/dump	./etc/frecover	./etc/fsclean
./etc/fsdb	./etc/getty	./etc/link
./etc/mvdir	./etc/ncheck	./etc/newfs
./etc/restore	./etc/savecore	./etc/setmnt
./etc/shutdown	./etc/unlink	./etc/recover1
./etc/fbackuprdr	./etc/fbackupwrtr	./lib/as_msgs.cat
./lib/cpp.ansi	./lib/dyncall.o	./lib/ccom
./lib/pcc_prefix.s	./lib/libH.a	./lib/libm.a
./lib/measure.o	./lib/milli.a	./lib/crt0.o
./lib/cpp	./lib/libcurses.sl	./lib/libc.a
./lib/dld.sl	./lib/libH.sl	./lib/libm.sl
./lib/libc.sl	./lib/libp/libmalloc.a	./lib/libp/libH.a
./lib/libp/libm.a	./lib/libp/libc.a	./lib/libp
./lib/crtx.o	./lib/crt1.o	./lib/libPW.a
./lib/libld.a	./lib/gcrt0.o	./lib/mcrt0.o

6-22 Troubleshooting

Troubleshooting Hints

This section outlines frequent types of situations that won't allow a system to successfully boot.

The files discussed in the following sections have paths that are *relative* to your root volume (*/*). They must be mounted at one of the mount points provided, and any absolute path names in which they appear must include the mount point. For example, if the root volume (*/*) is mounted at */mnt1*, the absolute path to */etc inittab* is this:

```
/mnt1/etc/inittab
```

Problems with Device Files

HP-UX needs a minimum set of device files to successfully boot. These files can be corrupted or even removed. If this happens, the system can't boot.

HP-UX needs:

- */dev/console*
- */dev/syscon*
- */dev/systty*
- */dev/tty*
- */dev/null*
- */dev/mem*
- */dev/kmem*

All of the files can be created as follows:

```
/etc/mknod /dev/console c 0 0x000000
/etc/mknod /dev/syscon c 0 0x000000
/etc/mknod /dev/systty c 0 0x000000
/etc/mknod /dev/tty c 0 0x000000
/etc/mknod /dev/null c 0 0x000002
/etc/mknod /dev/mem c 0 0x000000
/etc/mknod /dev/kmem c 0 0x000001
```

Problems with /etc/inittab

HP-UX requires a good `/etc/inittab` file in order to boot. This file can be removed or corrupted. If this is the case, HP-UX cannot boot. Following is a copy of a good `/etc/inittab` file. You may wish to create this file to boot your system. You may wish to use the following steps:

1. Type these two commands:

```
$ /etc/mv /etc/inittab /etc/inittab.old
$ vi /etc/inittab
```

2. Enter the following in `/etc/inittab`:

```
init:2:inittdefault:
stty::sysinit:stty 9600 clonal icanon echo opost onlcr ienqak ixon icrnl ignpar </dev/systty
brcl::bootwait:/etc/bcheckrc </dev/console >/dev/console 2>&1 # fsck, etc.
brc2::bootwait:/etc/brc >/dev/console 2>&1 # boottime commands
link::wait:/bin/sh -c "rm -f /dev/syscon; ln /dev/systty /dev/syscon" >/dev/console 2>&1
cwr::bootwait:cat /etc/copyright >/dev/syscon # legal requirements
rc ::wait:/etc/rc </dev/console >/dev/console 2>&1 # system initialization
powf::powerwait:/etc/powerfail >/dev/console 2>&1 # power fail routines
lp ::off:nomhup sleep 999999999 </dev/lp & stty 9600 </dev/lp
cons:13456:respawn:/etc/getty -h console console # system console
```

Problems with /etc/checklist

Your system may not boot if your disks could not be mounted to provide swap for your system. If this is the case, `/etc/checklist` may be missing or corrupt. Here is an sample `/etc/checklist` file:

```
# Sample /etc/checklist file. (see CHECKLIST(4)).
/dev/dsk/6s0 / hfs defaults 0 1 # root volume
/dev/dsk/5s0 /usr ignore defaults 0 2 # sample of 2nd entry
```

You may need to create the device files:

```
/etc/mknod /dev/dsk/6s0 b 7 0x201600
```

Problems with /etc/passwd

If the system boots and you see a `login:` prompt, but you can't log in as `root`, the `/etc/passwd` file may be missing or corrupt. The following entry can be put into `/etc/passwd` to provide a login for `root`. This specific entry does not require a password.

```
root::0:3:/:/bin/sh
```

6-24 Troubleshooting

Dealing with Hardware Faults

If your system still fails to boot, match the LED pattern that you had noted in the list of steps in Table 6-2 earlier in this chapter against those listed in Table 6-5 and take the recommended action.

If the action has no effect, contact your designated service representative for assistance.

LED Error Codes

This section contains information about the error codes displayed by the LEDs that are located behind the fold-away corner bezel (see Figure 6-1). There are eight amber LEDs and two green LEDs. One green LED indicates whether the power is on or off. It is not labeled. The other green LED indicates whether or not the service mode has been activated. It is labeled “Service,” and it is placed next to the service-mode switch. The service mode is used only during manufacturing.

The eight amber LEDs (labeled 8—1) display different patterns that correspond to a variety of hardware error conditions.

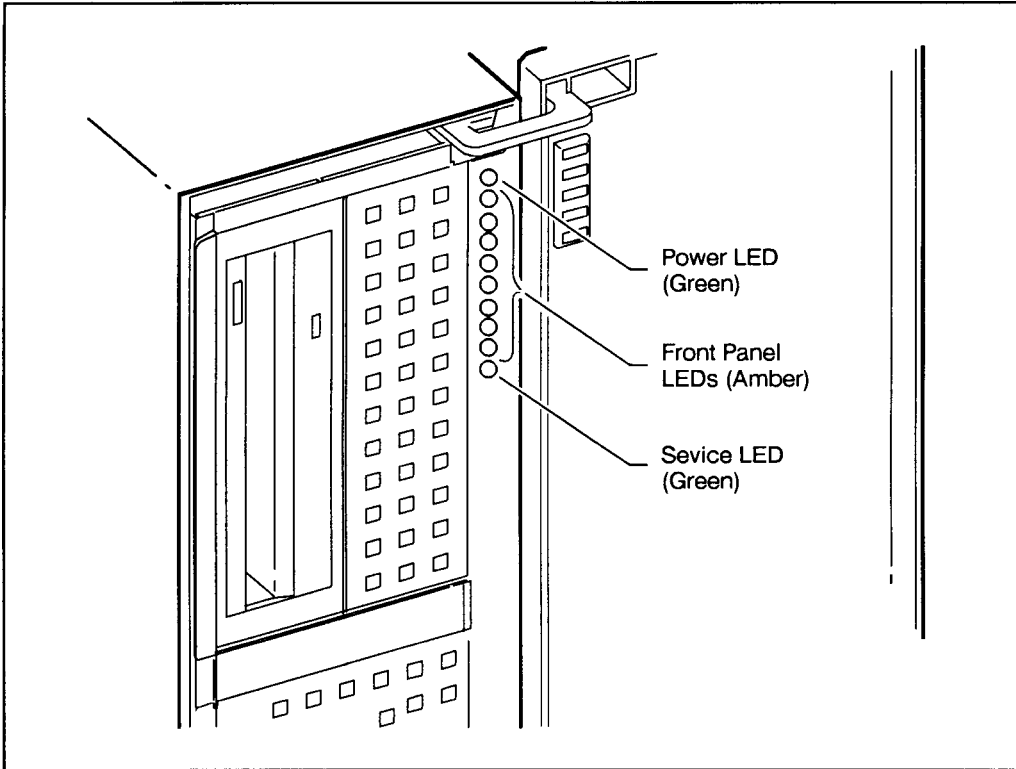

LG200193_023

Figure 6-1. LED Array

Component Error Codes

Table 6-5 lists some of the LED display patterns generated by the selftests that your computer runs on its processor, memory, input/output, and graphic interface cards. Usually, these patterns will flash by quickly. However, if your computer cannot complete its booting process, and one of these patterns is displayed on the LEDs, it may be necessary to take some corrective action.

The patterns in Table 6-5 indicate that there is something seriously wrong with one of the components of your computer. If your computer “freezes up” while it is booting and displays one of the patterns in this table, you must replace one or more of the system’s components.

Note	The LED patterns displayed during the selftests are not related in any way to the patterns described in “Understanding the LEDs” in Chapter 1. Those patterns apply only when the system has successfully booted HP-UX.
-------------	---

**Table 6-5.
LED Codes Which Indicate That a Component Must Be Replaced**

8 7 6 5 4 3 2 1	Component To Be Replaced
o o o x e e e e	System card
o o x o e e e e	System card
o o x x e e e e	System card
o x o o e e e e	System card
o x o x e e e e	System card
o x x o o o o o	SIMM card in slot J100
o x x o o o o x	SIMM card in slot J101
o x x o o o x o	SIMM card in slot J102
o x x o o o x x	SIMM card in slot J103
o x x o o x o o	SIMM card in slot J104
o x x o o x o x	SIMM card in slot J105
o x x o o x x o	SIMM card in slot J106
o x x o o x x x	SIMM card in slot J107
o x x o x o o o	SIMM card in slot J108
o x x o x o o x	SIMM card in slot J109
o x x o x o x o	SIMM card in slot J110
o x x o x o x x	SIMM card in slot J111
x o x x o o x o	System card
x o x x o x o x	System card
x o x x o x x o	System card <i>or</i> one of the SIMM cards
x o x x o x x x	System card
x o x x x o o e	System card
x = ON, o = OFF, e = either ON or OFF	

Running the SAX (System Acceptance Executive) Tests

SAX is an online system-level exerciser. You will use SAX in its CIT (Customer Installation Test) mode to verify that your system is correctly installed and configured.

You must have permission to access the `/etc/diag` directory. If you receive a message that you do not have access rights to this directory, change them.

- If you have superuser login privileges on your computer, log in as `root` and use the `/bin/chmod` command to allow access to the directory. See *A Beginner's Guide to HP-UX* and the manual page for `chmod(1)` in *HP-UX Reference* for information on `/bin/chmod`.
- If you do not have superuser privileges, contact your system administrator to arrange your access to the `/etc/diag` directory.

1: Insert Writable Media

SAX includes tests of any drives that accept removable media (such as a DAT tape drive). If you have peripherals that accept removable media, be sure to insert a write-enabled medium in the drive before running SAX in CIT mode. If you do not, SAX will not be able to complete its tests.

2: Invoke SAX

To run the SAX tests, type:

```
$ cd /etc/diag/sax
$ /etc/diag/sax/sax -cit
```

If you are running the SAX tests from a windowing environment, the program will open many windows on the screen. These will display information about the conduct of the tests.

3: Track the Progress of the SAX Run

The Tracker window, which appears at the bottom of the display when SAX runs in a windowing environment, shows information about your system, including:

- the node ID and network name

- elapsed run time of the tests
- current time (by the system clock)
- the time at which the tests were started
- system loading information

The last item, system loading, is measured in terms of the number of microseconds it takes to do a unit of work. The system load has a **threshold value**, and whenever this value is exceeded, a **system overload** occurs, and an overload indicator appears in the Tracker window. It's important to be aware of overloads, because any errors that appear during an overload are usually attributable to the overload and *not* to a hardware error.

4: Note Any Errors

If an error occurs, it is reported in the Supervisor window. Such errors have the following format:

```
*** Error detected by Test Process "device_error_code"
during SAX pass x, Test Process pass y.
Current time: mm/dd/yy hh/mm/ss
Elapsed runtime: hhh:mm:ss
Loading: Average = xxx.xx, Discrete = xxx.xx, Threshold = xxx.xx
Logfile pathname: //working_directory_pathname/device_error_code/device_error_code.log
Error text from test process...
```

Make careful note of these errors and the names of the log files in which they are stored. They will be useful in identifying which component (if any) you must remove to correct the error condition.

If you need assistance in understanding or acting upon the error messages produced by the SAX tests, contact your designated service representative.

For Further Information

Using DEX and SAX with HP-UX (HP part number A1926-90002) is a useful document to have if you intend to perform extensive diagnostic tests on your computer.

6-30 Troubleshooting

Calling for Service

If you have a problem that is not dealt with in this manual, contact your designated service representative for assistance.

When calling for service, always have your system's model and serial number ready.

— |

| —

— |

| —

Index

A

address, station, 2-2

B

battery, lithium
 replacement, **5-12-13**
boot administration commands, 6-1
boot device, 6-6
boot failure, 6-6-7
booting the computer, 2-1, 2-3
buttons
 minimize, 2-8
 window menu, 2-8

C

clicking the mouse, 2-8
cluster, connection to an HP-UX, 2-1
color graphic card bulkhead, 1-10
color monitor, 1-15
command
 mkrs, 4-2-6
commands
 cp, 3-11, 3-12
 “fsck”, 6-8, 6-10
 mv, 3-11, 3-12
commands, boot administration, 6-1
component replacement, **5-1**
computer
 installing options, **5-10-15**
connectors on EISA cards, access to,
 1-14
console icon, 2-8

console terminal, 1-15
control panel, 2-8
copying
 files, 3-6
copyright screen, 2-7
cp command, 3-11, 3-12
creating
 recovery system, 4-2-6

D

data
 recovering, 4-2-6
directories
 moving and copying files with **mv** and
 cp, 3-11, 3-12
disk activity LED, 1-4
disk drives, external, 2-3
disks, external
 termination, 5-23
disks, internal
 replacement, **5-23-33**
display, video, 1-15
double-clicking the mouse, 2-8

E

EISA card
 installation, **5-18-22**
 removal, **5-18-22**
 replacement, **5-18-22**
EISA card bay
 faceplate access, 1-14
expanding the computer, **5-1**

external disk drives, 2-3
external peripherals, 2-3

F

faceplates of EISA cards, 1-14
file manager
 opening, 3-4
files
 copying, 3-6
 copying between directories, 3-11,
 3-12
 moving, 3-5
 moving between directories, 3-11,
 3-12
file system failures, 6-7
fsck command, 6-8, 6-10

G

graphic interface bulkhead, 1-10
graphics card
 replacement, **5-16-17**
grayscale graphic card bulkhead, 1-10
grayscale monitor, 1-15

H

“heartbeat” LED, 1-4
host name, 2-2, 2-6
HP-UX
 file system, protecting, 4-1-9
HP-UX operating system, 2-3
*HP Visual User Environment User's
 Guide*, 2-38
HP VUE
 starting up, 2-1

I

icon
 console, 2-8
installing the computer, 2-1
internet protocol address, 2-2
IP address, 2-2

Index-2

ISA card
 installation, **5-18-22**
 removal, **5-18-22**
 replacement, **5-18-22**

L

LAN, 802.3 LAN
 changing types, **5-14-15**
LED. disk activity, 1-4
LED display
 location, 1-4
 used for troubleshooting, 6-1, 6-25,
 6-28
 used in troubleshooting, 6-3
LED, “heartbeat”, 1-4
LED, power
 not illuminated when power is turned
 on, 6-2
LED. power, 1-4
LED, “receiving from LAN”, 1-4
LED, “transmitting to LAN”, 1-4
logging in, 2-3, 2-4

M

minimize button, 2-8
mkrs, 4-2-6
monitor, 2-3
 brightness control, 6-3
monitor, color, 1-15
monitor, grayscale, 1-15
mouse actions
 clicking, 2-8
 double-clicking, 2-8
moving
 files, 3-5
mv command, 3-11, 3-12

N

network connection, 2-1
networking
 host name, 2-2

- station address, 2-2
- system name, 2-2

O

- operating system, HP-UX, 2-3

P

- password
 - setting, 2-30
 - setting with VUE, 2-30
- peripherals, external, 2-3
- powering up the computer, 2-1
- power LED, 1-4
- power on/standby switch, 2-2
- power supply bulkhead, 1-9
- power switch, 1-7

R

- “receiving from LAN” LED, 1-4
- recovering data
 - creating a recovery system, 4-2-6
- recovery system, 6-8
 - booting, 6-9
 - creating, 4-2-6
 - device files, 4-5, 4-6
 - security, 4-4
 - using, 6-10
- replacement of components, **5-1**
- reset switch, 1-7
- restoring a damaged file system, 6-8-10
- root user, 2-5

S

- SAX, 6-1, 6-5, 6-29
- server configuration, 2-1
- service/normal switch, 1-7
- setting up
 - recovery system, 4-2-6
- SIMM card
 - installation, 5-10
 - replacement, **5-10-11**

- updating, 5-10
- starting up the computer, 2-1
- station address, 2-2
- switch
 - power on/standby, 2-2
- switches, 1-7
- System Acceptance Test, 6-1, 6-5, 6-29
- system bulkhead, 1-7
- system card
 - replacement, **5-6-9**
- system console, 1-15
- system name, 2-2, 2-6
- system unit
 - back, 1-6
 - defined, 1-2
 - powering down, **5-5**
 - power switch, 1-7
 - service/normal switch, 1-7
 - static electricity, **5-3**
 - switches, 1-7
 - TOC switch, 1-7

T

- terminal, console, 1-15
- terminal window, 2-9
- The HP Visual User Environment System Administration Manual*, 2-38
- time zone, 2-2
- “transmitting to LAN” LED, 1-4
- troubleshooting, **6-1-31**
 - boot failure, 6-3, 6-6-7
 - computer can not be turned off, 6-2
 - computer hangs, 6-1, 6-4, 6-5
 - computer unresponsive, 6-2
 - file system failures, 6-7
 - hard crash, 6-2
 - HPMC error, 6-2
 - intermittent operation, 6-5
 - network problems, 6-4
 - operating system does not load, 6-1, 6-3

restoring a damaged file system,
 6-8-10
strategies, 6-1
system unresponsive, 6-1
turning on the computer, 2-1

U

Using the X Window System, 2-38
utility
 mkrs, 4-2-6

V

video display, 1-15
VUE
 setting password, 2-30

W

window menu button, 2-8
window objects
 console icon, 2-8
 control panel, 2-8
 terminal window, 2-9
 workspace manager, 2-8
workspace manager, 2-8